

# INNOVATION ECOLOGY

MILWAUKIE ALIGNMENT PORTLAND, OREGON

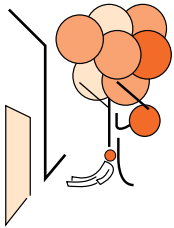

URBAN LANDSCAPE ARCHITECTURE

EVAN STRAVERS

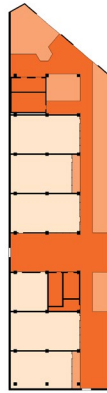

BUILDING ARCHITECTURE

RICHARD WILSON

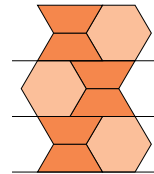

FACADE ARCHITECTURE

JEFF LANDRIE

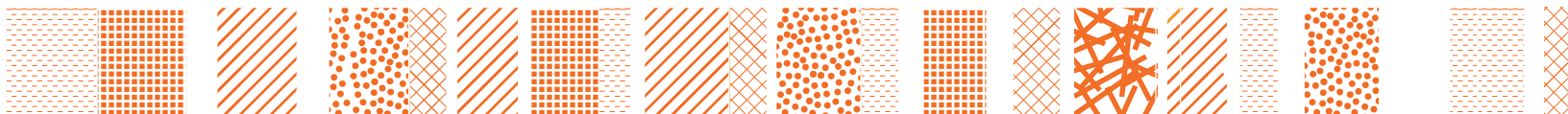

# EXPERIENCE CATEGORIES

How do residents and visitors experience and appreciate the community around them?

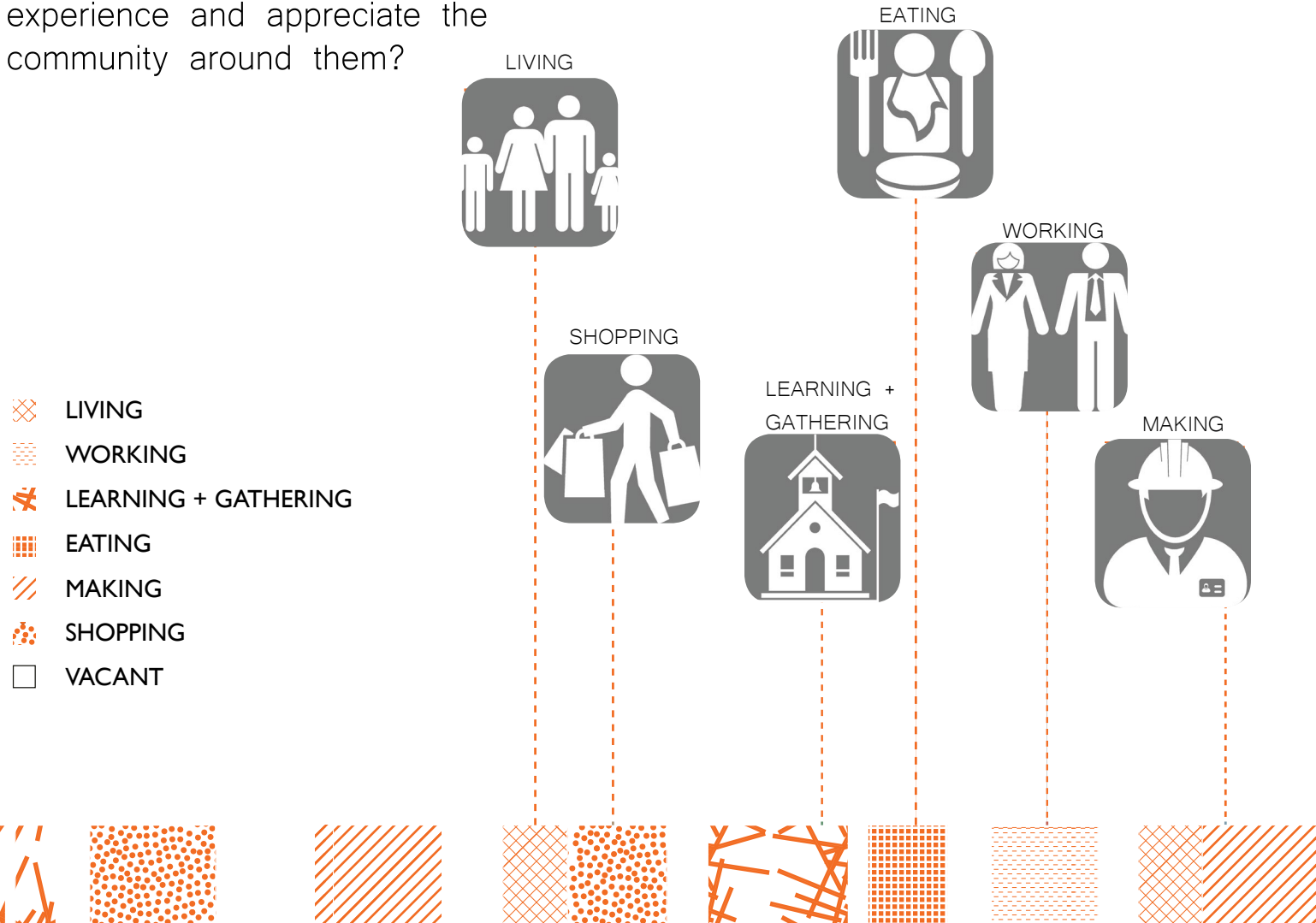

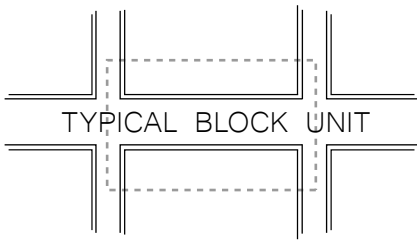

Clinton Station  
Neighborhood,  
Portland

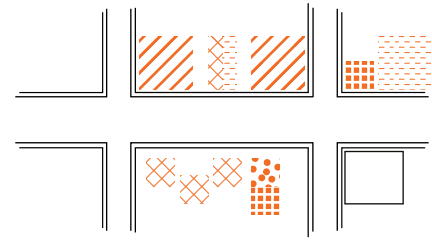

Belmont/Hawthorne  
Neighborhood,  
Portland

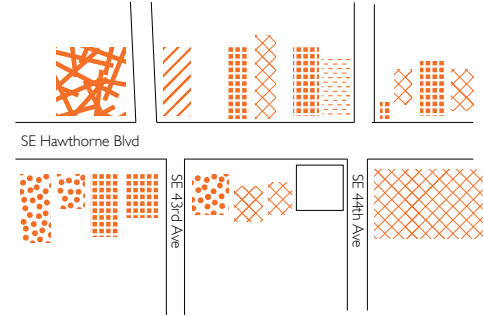

The Eixample, Barcelona

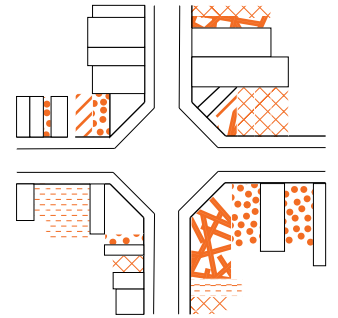

-  LIVING
-  WORKING
-  LEARNING + GATHERING
-  EATING
-  MAKING
-  SHOPPING
-  VACANT

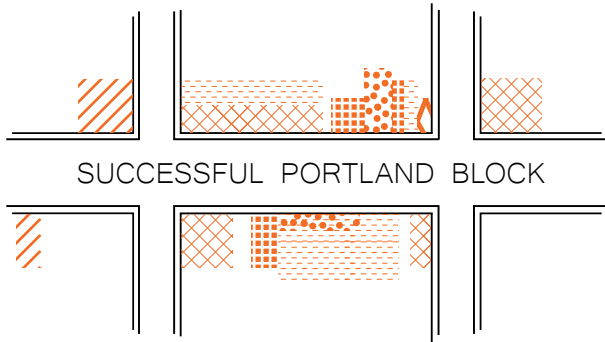

# SITE CONTEXT

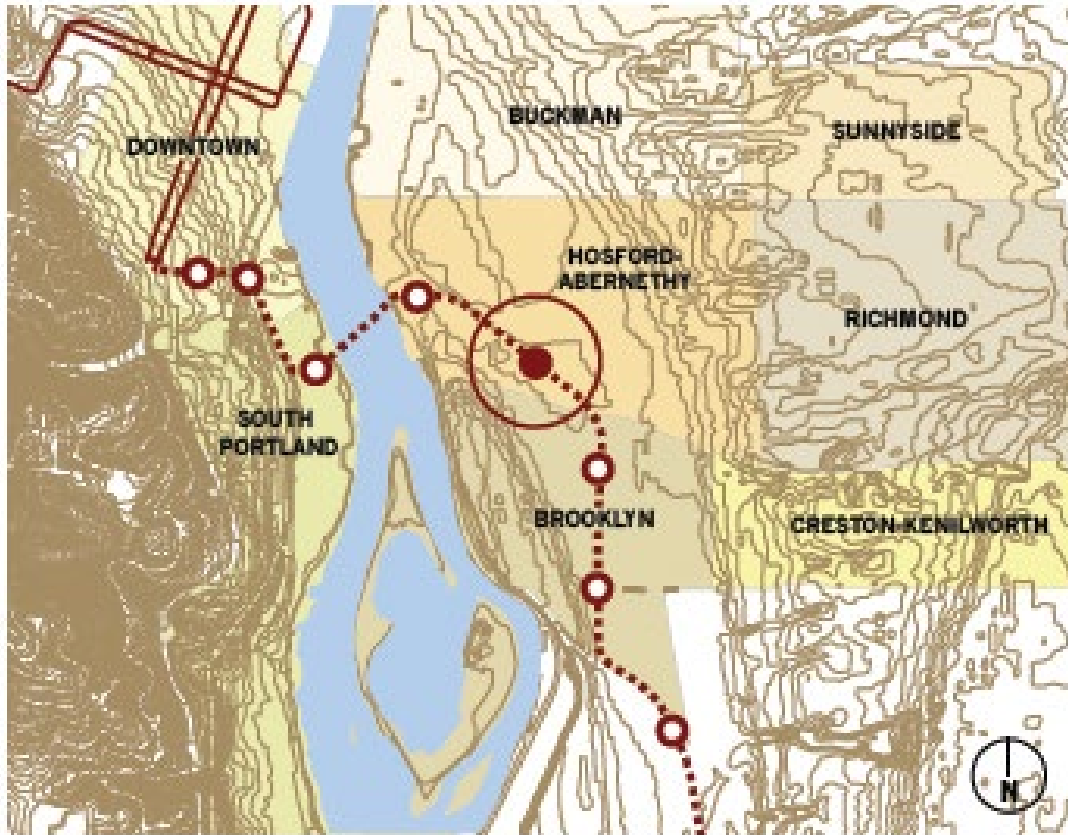

Neighborhood homes



Ford Building and grassy lot adjacent Union Pacific Railway



Danigold facilities



Fire Station Tower



Existing freight bisecting the station area



# SOUTHEAST PORTLAND

3X3 test area located in Southeast Portland along the intesecon of SE Division St & SE 12th Ave

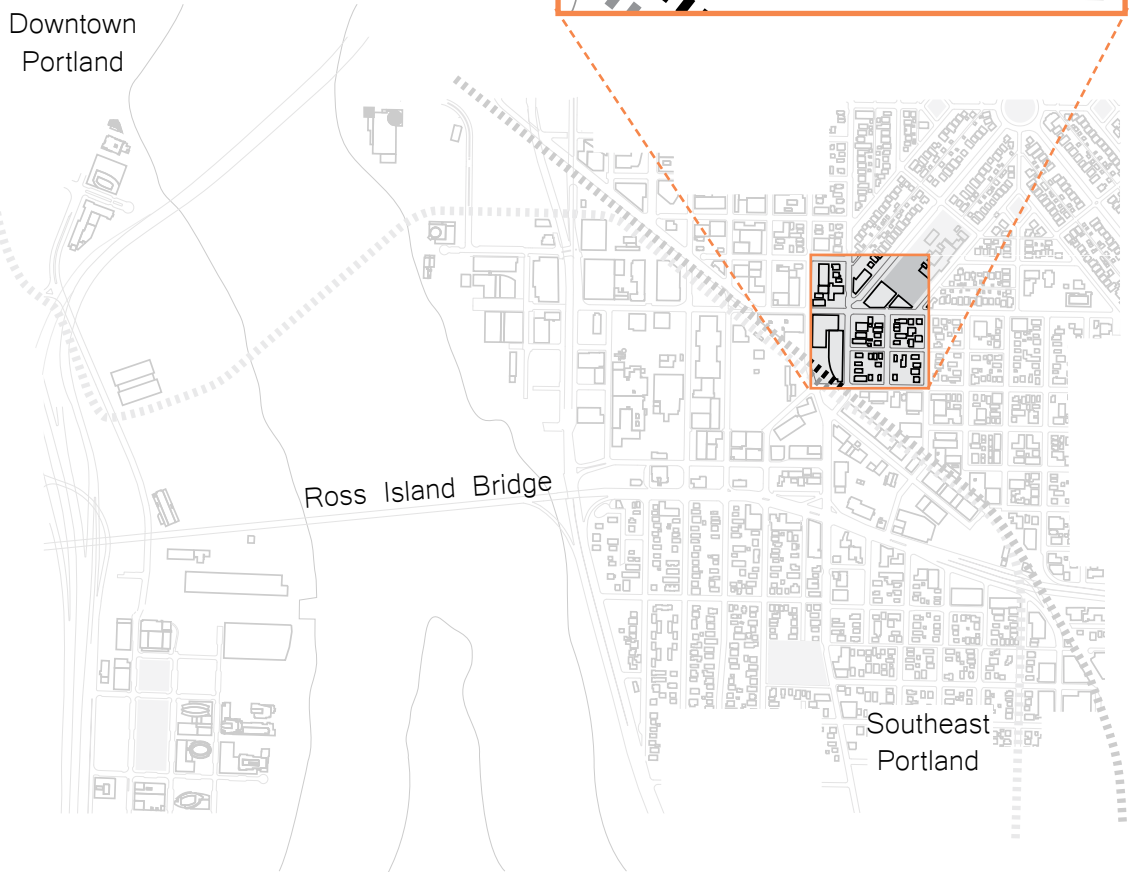
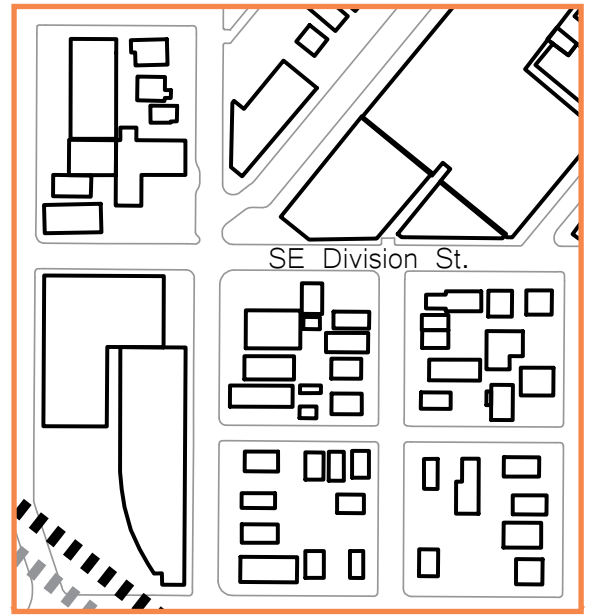

District Plan  
1"=400'-0"









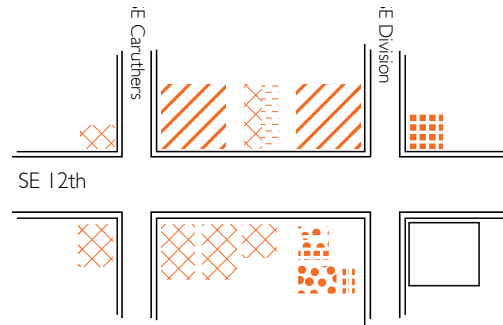

# REALISTIC CONDITIONS

A true reflection of the **developing neighborhoods** in Portland's East side.

Studying actual block composition allowed us to develop more **nuanced views** of what actually occurred in new developments.

These diagrams show how varied streets can be from block to block, reflecting our anecdotal **understandings** about the makeup of city blocks by themselves and on the whole.



	living	35%
	working	6%
	learning	0%
	eating	24%
	making	12%
	shopping	17%
	vacant storefronts	6%

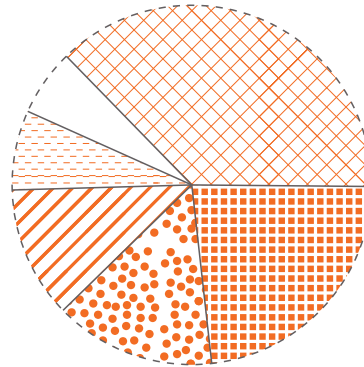

# NEIGHBORHOOD BUILDING USE

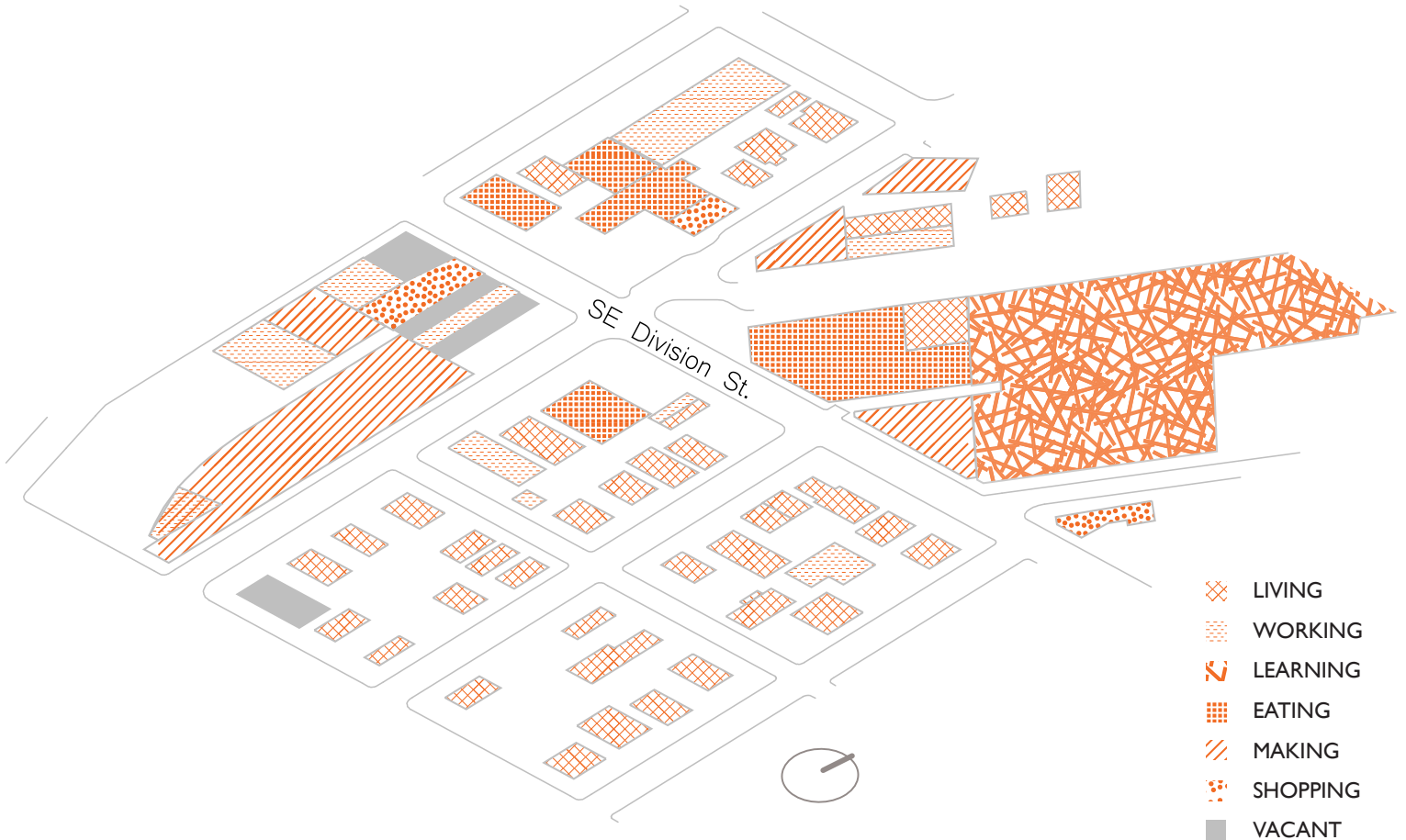

Building use in the test block can be seen in relation to one another from the standard top down view.

At the scale of the three block square, we can see how a successfully developed neighborhood has a stabilizing mix of uses that support the lives of it's residents.

# BOTTOM-UP MAPPING

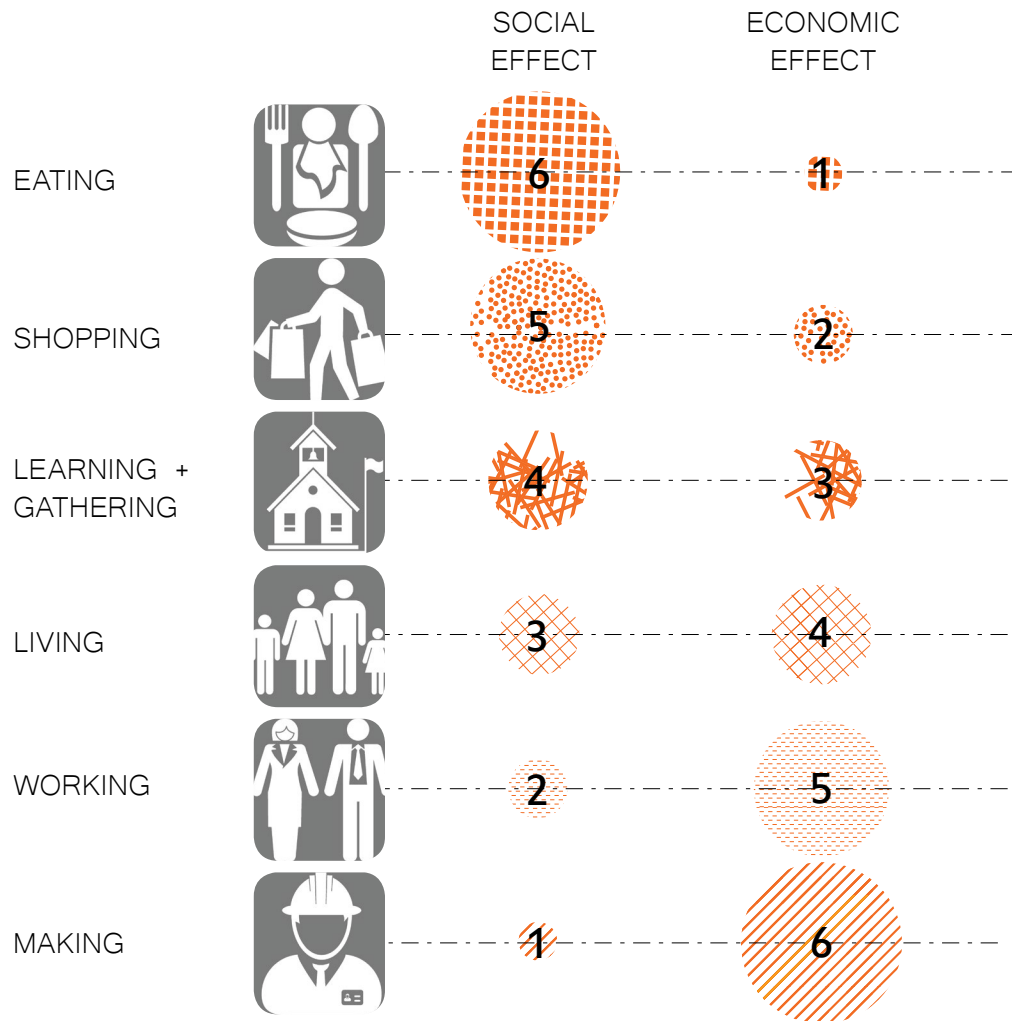

A bottom-up look at how uses interact with each other. By projecting the economic and social diversity of an area into the surrounding space, we can begin to see what uses we would like to support with our urban designs.

Uses are ranked according to their level of spatial influence, then patterns are selected and ranked in order to communicate the relative intensity or ambiance of activity, whether social or economic.

# 3x3 URBAN ROOM SOCIAL DIVERSITY

Where are people with differing circumstances likely to inter-mix?

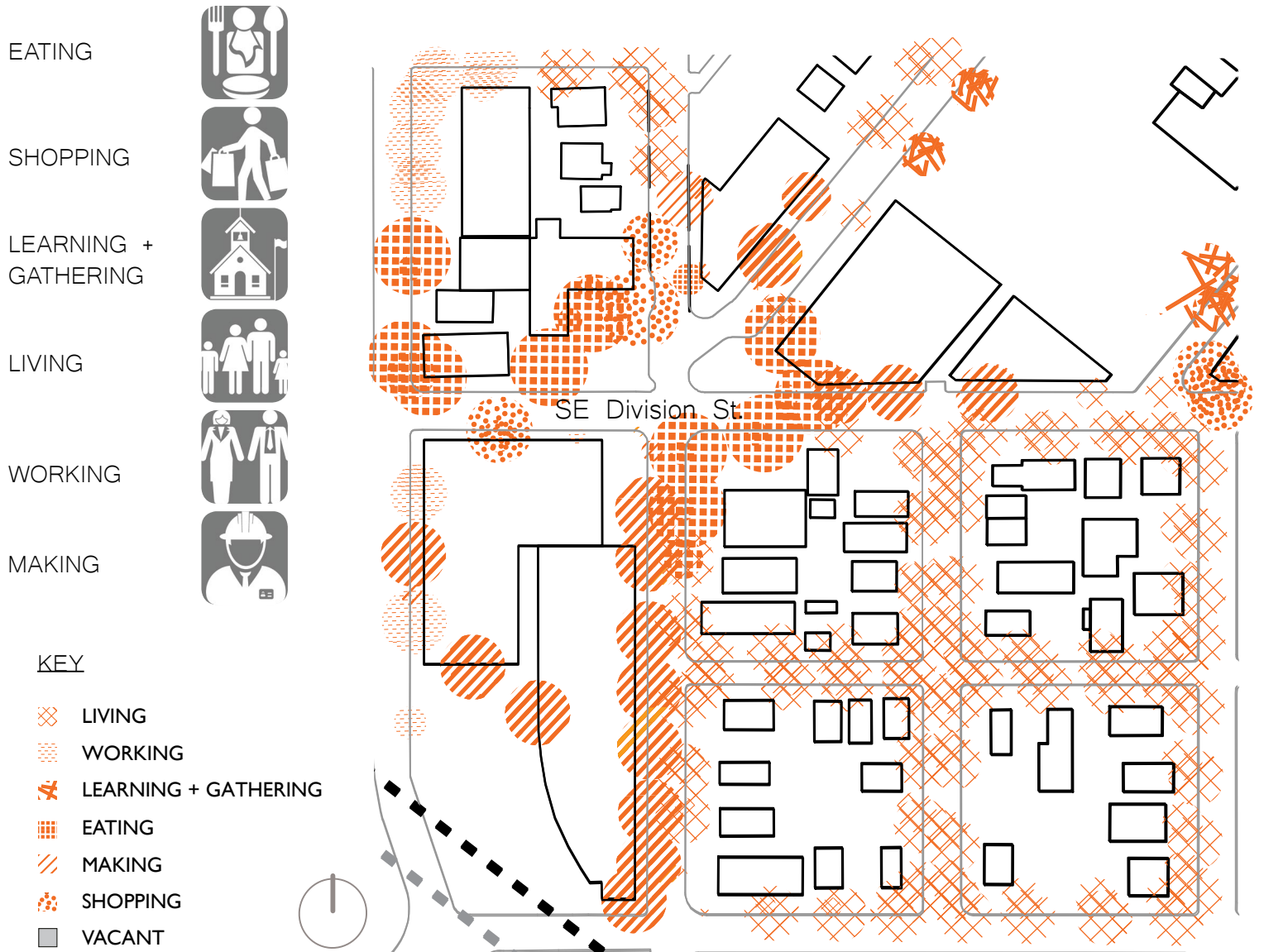



# INNOVATION ECOLOGY

1. Documentation and Analysis
2. Project Synthesis and System Development
3. Site Development
  - Envelope System
  - Urban Architecture
  - Building Development
4. Culmination

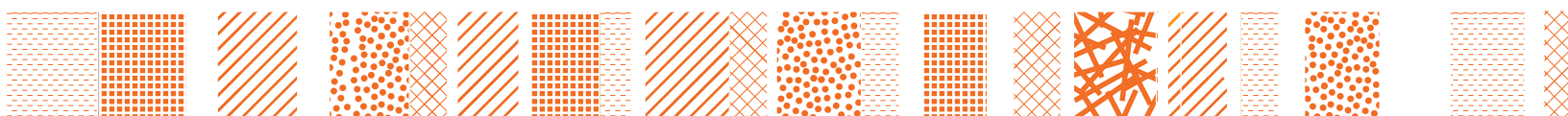

# MIX CRITERIA

For each urban room, we can analyse its use to determine how 'mixed-use' it is.

We then compared it to adjacent units and those across the street or within the viewable urban room.

The score is highest when each use occurs in a given area. Vacancy is not an active use and is not considered.

The highest score achievable by a block is 6 out of a possible 7 uses, or 86%.

This scoring method is then applied parametrically to create a heat map of the urban room it sits within.

Each vacancy also has an ideal state that will most positively improve the mix

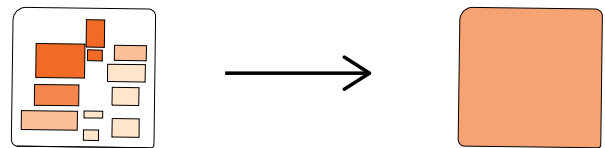
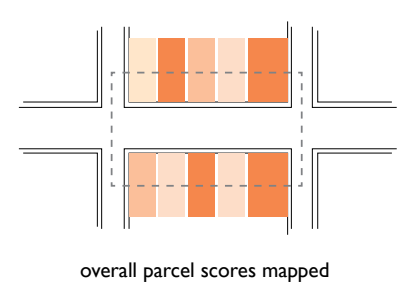
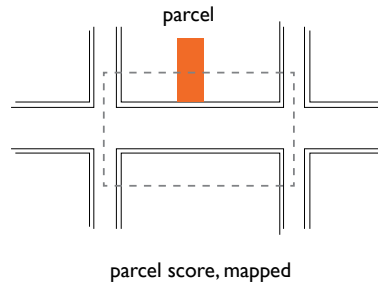
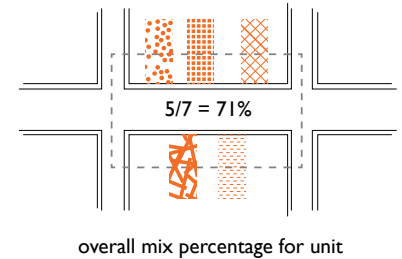
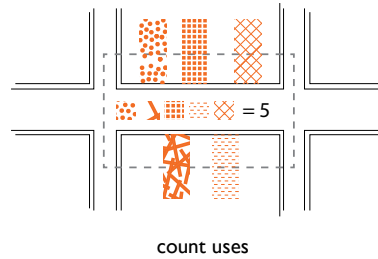
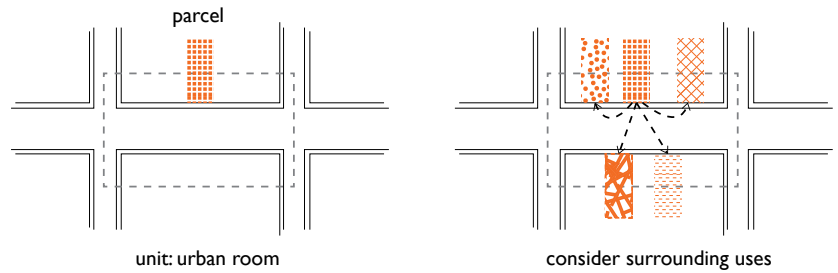

# NEIGHBORHOOD MIX BY BLOCK



# CLINTON STATION - URBAN ROOM ANALYSIS

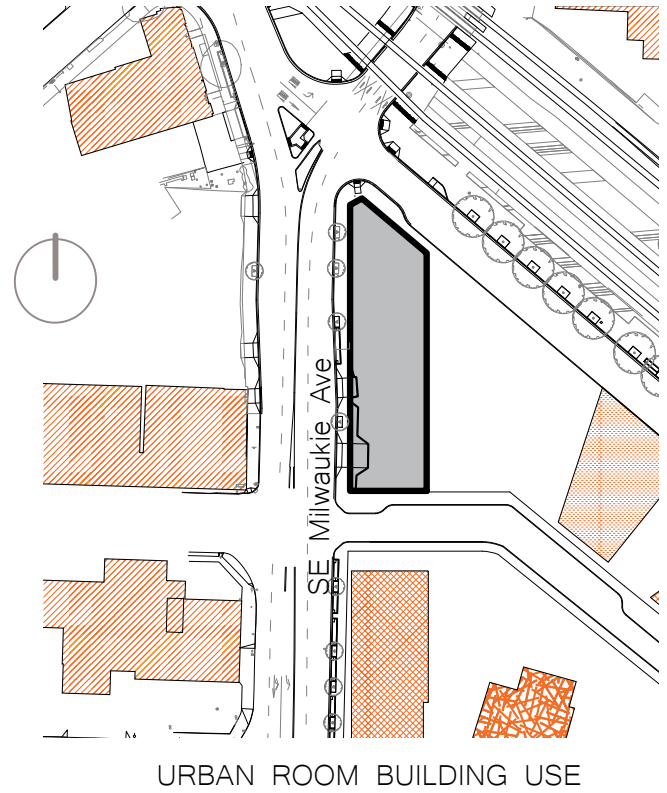
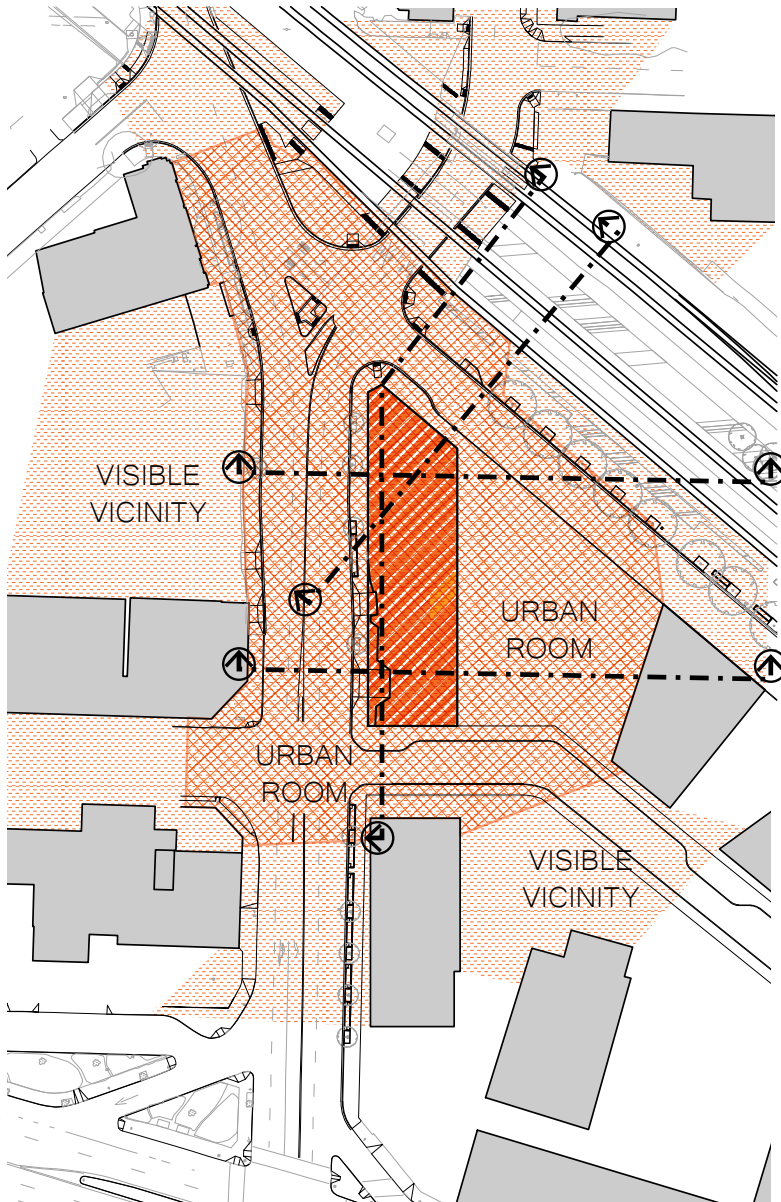

# CONCEPTUALIZING BLOCK DEVELOPMENT

We are also able to assess our target block and each use in the master plan for its development, **guiding our designs.**

Furthermore, the tool then can gauge the use mixture while the neighborhood is developing and once it has developed, allowing prospective business owners to make **informed decisions** about placement, design, and their relationship to the surrounding neighborhood.

When placing a new prospective business or residential unit, we can see how well it can increase the overall mix score for it's surroundings, whether it be that block, neighborhood, or district scale. This leads to more successful business starts, **strengthening the neighborhood fabric** on the whole.

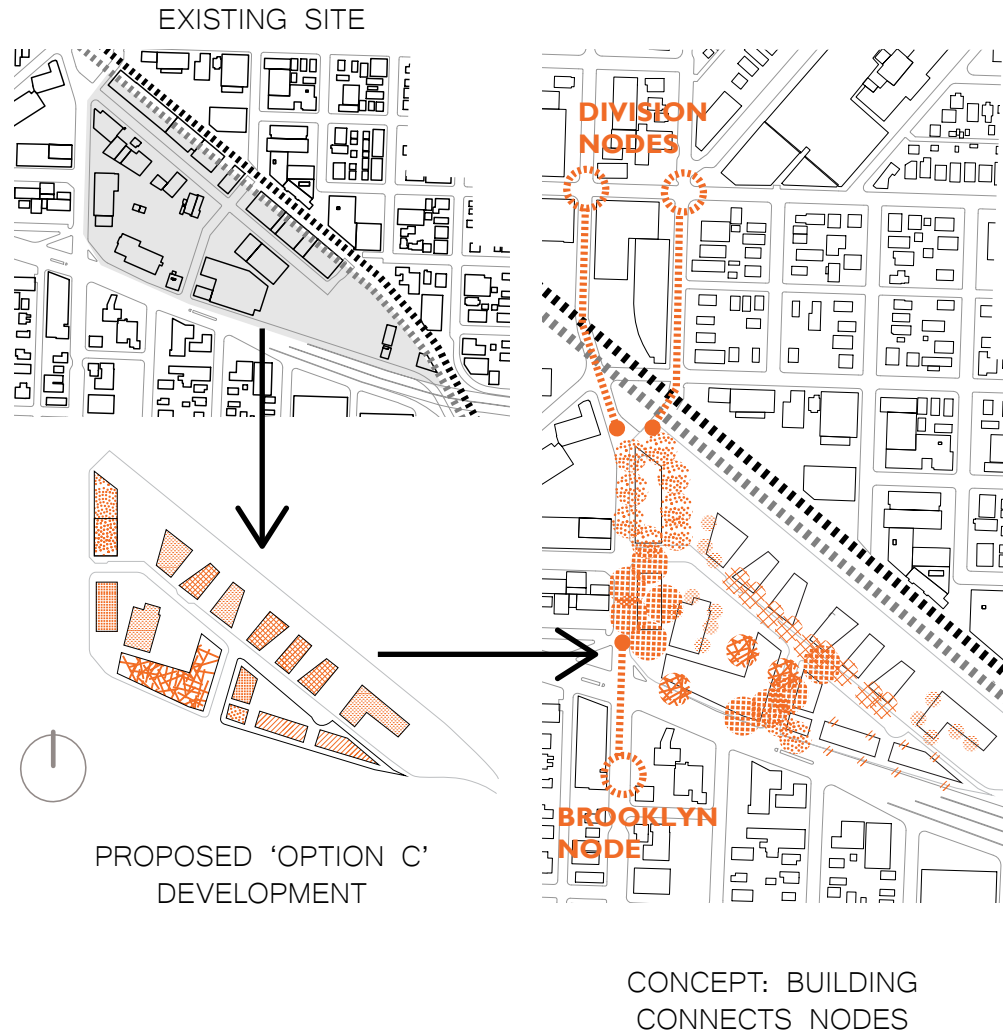



# MAKER DIVERSITY

We can lay the foundation for a building that helps **inspire new ideas** through the visualizing how diversity projects into common space.





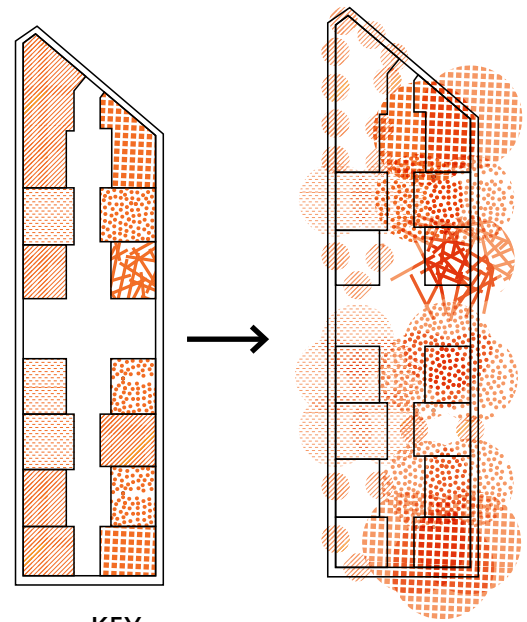

By studying diversity and its relationship with the built environment, we can begin to take the the same diversity that supports the vibrant Portland street life and use it to create a vibrant internal streetscape for the **dyanmic interface** of public and industrial program.

Similarly, the tool can be turned internally to look at how existing uses and the deployment of new businesses can create opportunities for quality third (mixing) spaces or other complimentary businesses.

## BUILDING DIVERSITY CONCEPT



### KEY

-  LIVING
-  WORKING
-  LEARNING + GATHERING
-  EATING
-  MAKING
-  SHOPPING
-  VACANT

## URBAN ROOM SECTIONS

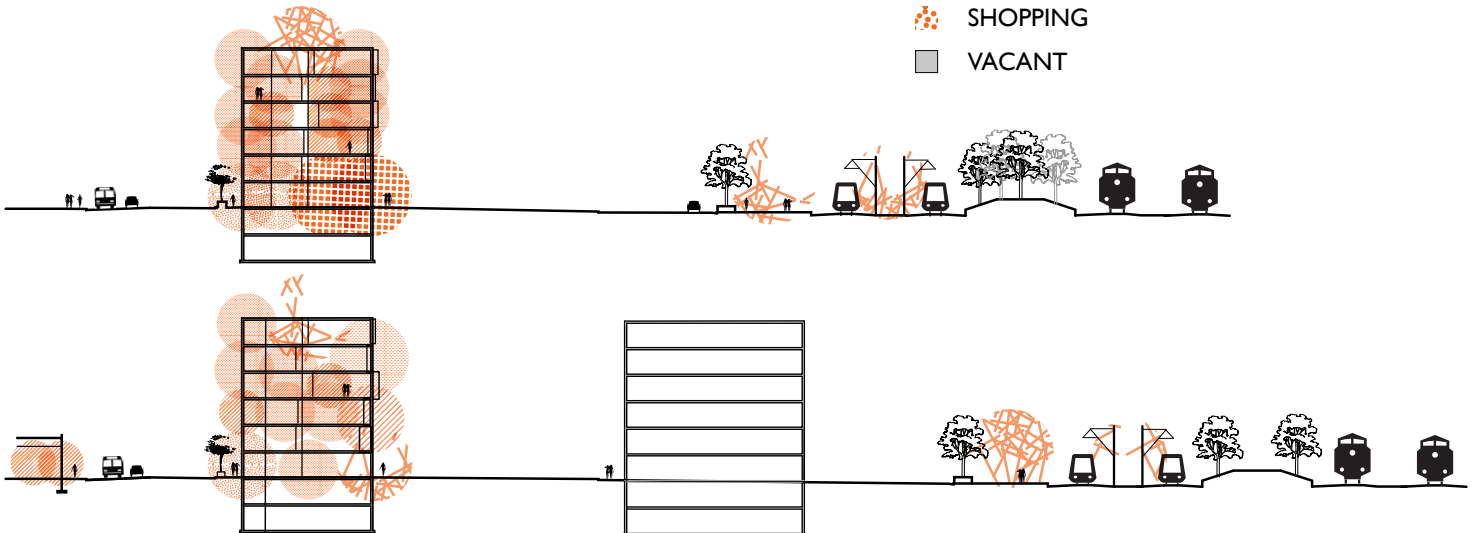

# PROGRAMMING

How the team approached the project together.

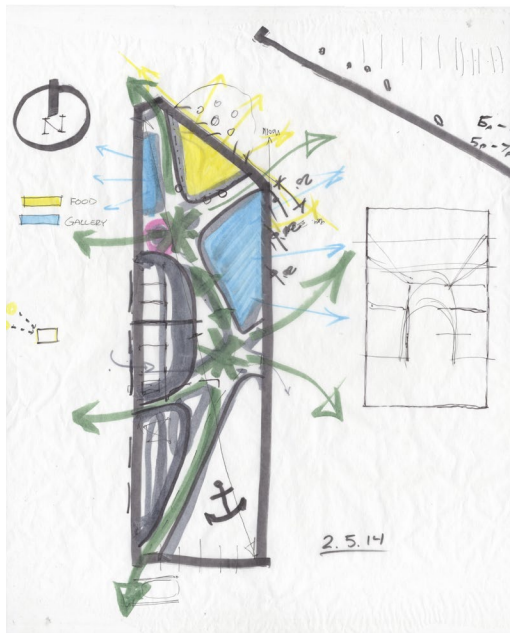
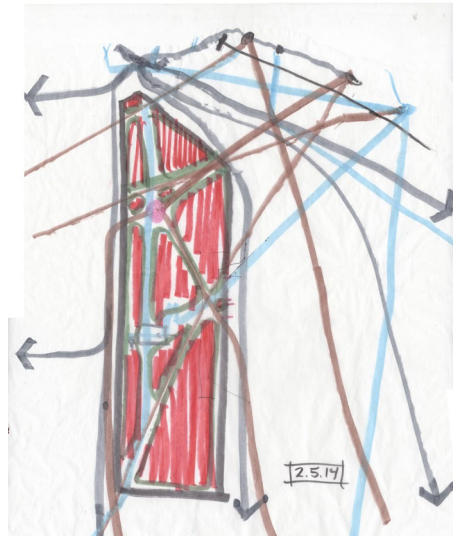

**Program Document: Values**

The following is a list of values that define the project potential, based on the subjective approach of the designer(s). Indicate which will be present during the chosen project; make notes and sketches as needed to refer back to for clarity later.

Hershberger, R. Architectural Programming and Pre-design Manager (1999).

Human	Environmental	Cultural	Technological	Temporal	Economic	Aesthetic	Safety
<ul style="list-style-type: none"> <li>● Functional</li> <li>● Social</li> <li>● Physical</li> <li>● Physiological</li> <li>● Psychological</li> <li>● Circulation</li> </ul>	<ul style="list-style-type: none"> <li>● Site</li> <li>● Climate</li> <li>● Context</li> <li>● Resources</li> <li>● Waste</li> </ul>	<ul style="list-style-type: none"> <li>● Historical</li> <li>● Institutional</li> <li>● Political</li> <li>● Legal</li> </ul>	<ul style="list-style-type: none"> <li>● Materials</li> <li>● Systems</li> <li>● Processes</li> </ul>	<ul style="list-style-type: none"> <li>● Growth</li> <li>● Change</li> <li>● Permanence</li> </ul>	<ul style="list-style-type: none"> <li>● Finance</li> <li>● Construction</li> <li>● Operations</li> <li>● Maintenance</li> <li>● Energy</li> </ul>	<ul style="list-style-type: none"> <li>● Form</li> <li>● Space</li> <li>● Color</li> <li>● Meaning</li> </ul>	<ul style="list-style-type: none"> <li>● Structural</li> <li>● Fire</li> <li>● Chemical</li> <li>● Personal</li> <li>● Criminal</li> </ul>

Bringing together merchants from around the world within easy reach.

Each designer brought a set of values into the project. Over time each of our values will come together in a mix of cohesive design focus.

Initial design programming centered around the pedestrian experience, and creating nodes within the building.

# FACADE INFLUENCES

Innovation inspires further development and improvement. The building envelope sets the tone for the function and purpose of the building, in hope to further inspire innovation.

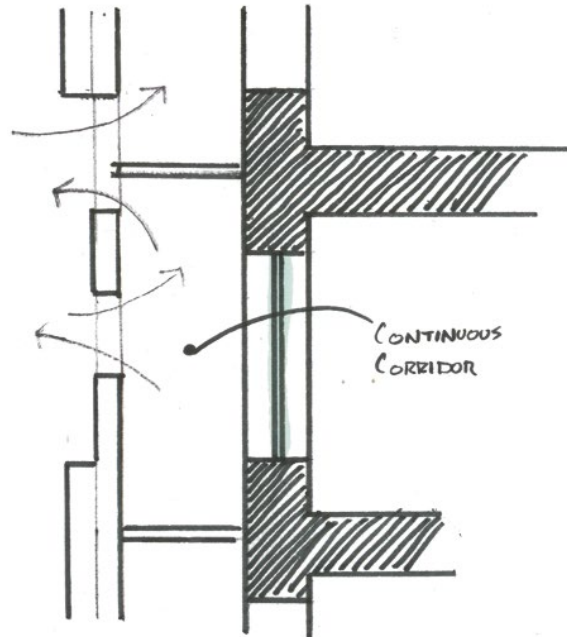
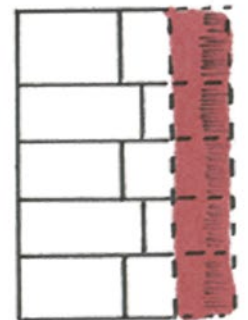
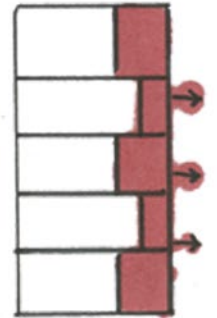
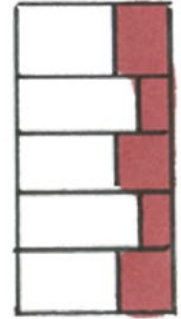
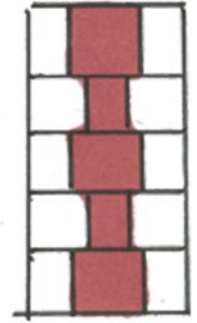
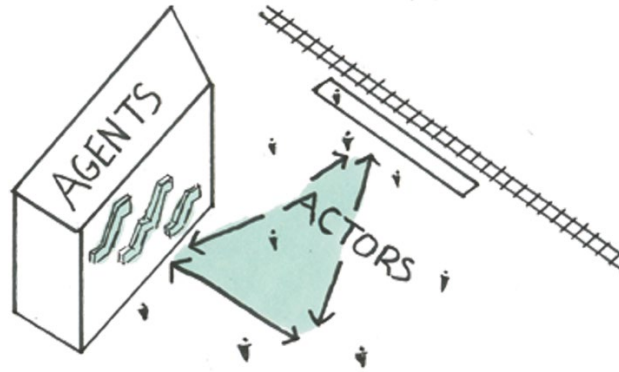

PASSIVE COOLING  
DOUBLE SKIN FACADE

# TECTONICS

Considering each unit's individual use, we can use our understanding of different phenomena to plan design interventions towards a vibrant, innovative building and urban room.

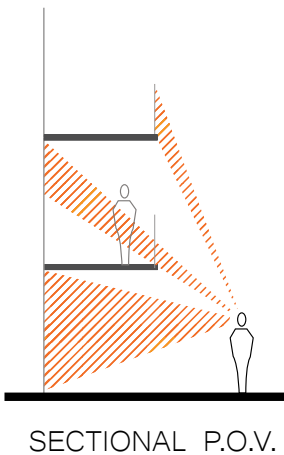
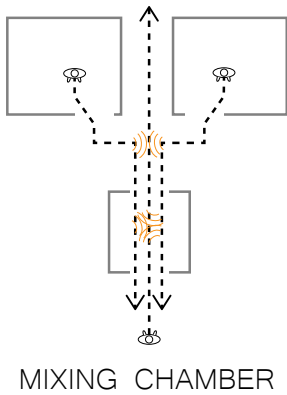
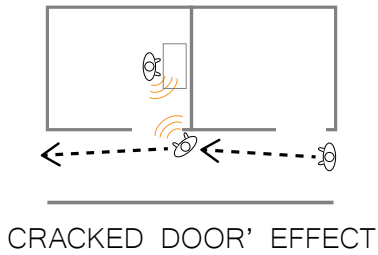
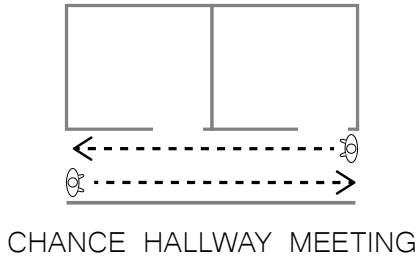

MATERIAL AFFECT SCENARIOS

INTERPRETATION  
+  
ANALYSIS

DESIGN INTERVENTION CONCEPTS

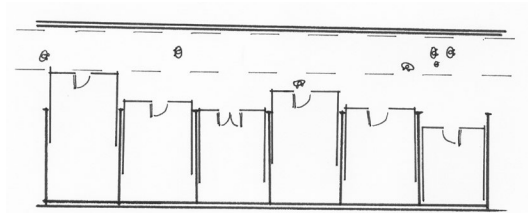
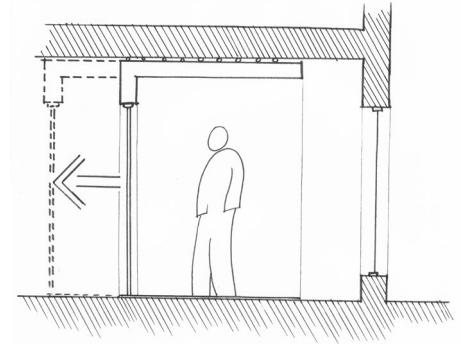

# INNOVATION ECOLOGY

1. Documentation and Analysis
2. Project Synthesis and System Development
3. Site Development
  - Envelope System
  - Urban Architecture
  - Building Development
4. Culmination

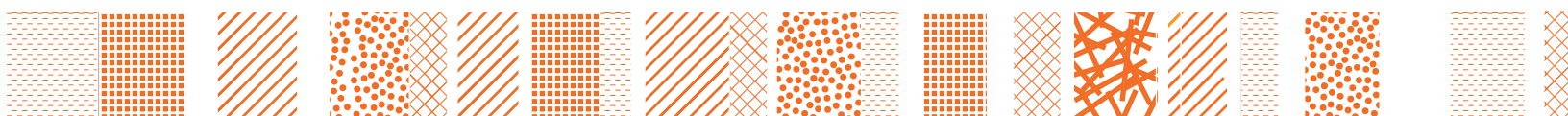
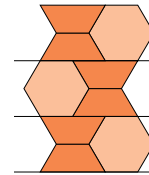



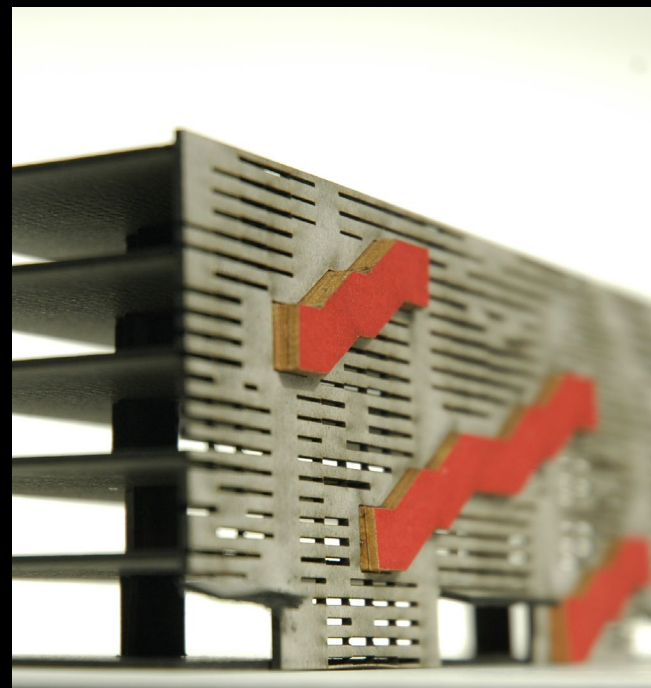
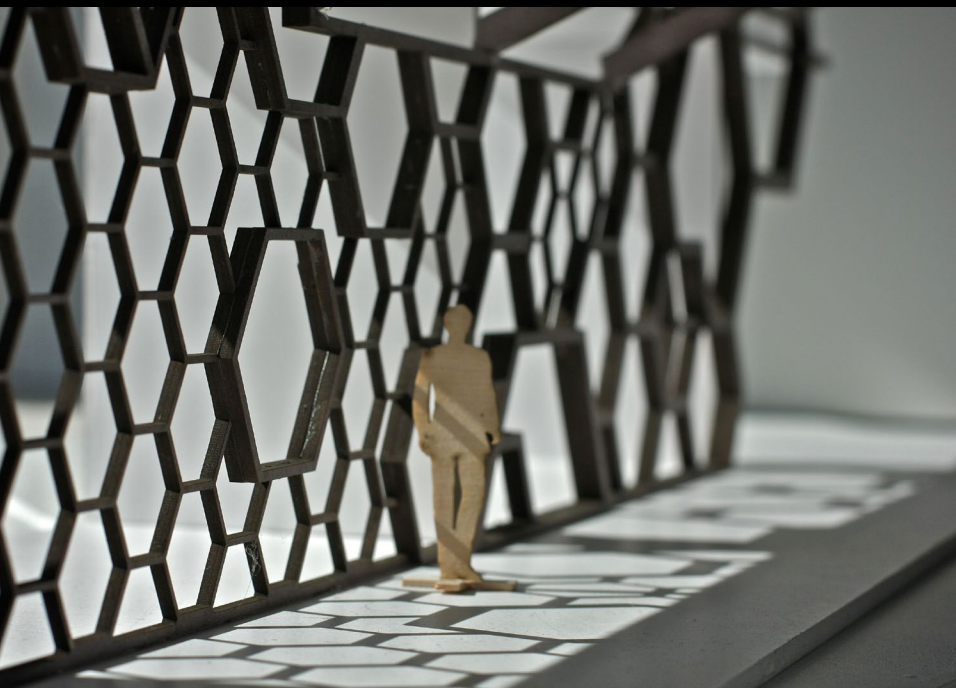

# ENVELOPE SYSTEM

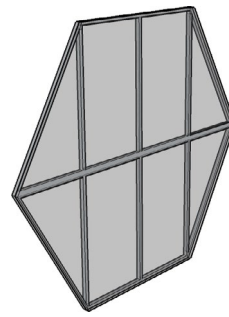
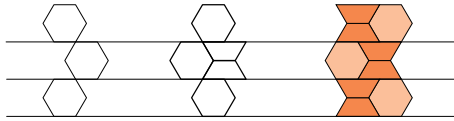
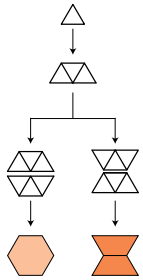

Typical standard unit

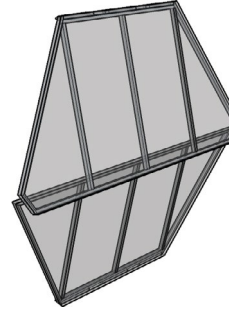
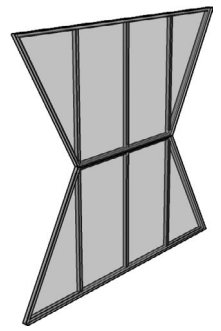

Typical standard unit ventilated

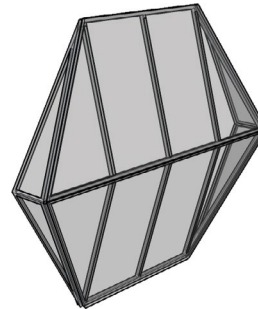

Aggregated units

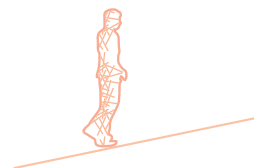
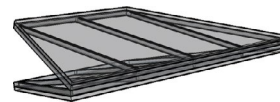
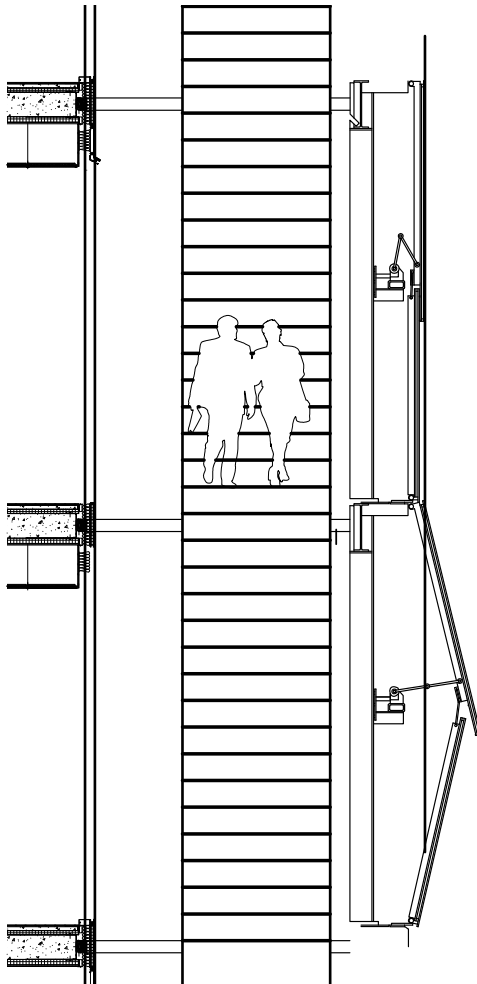
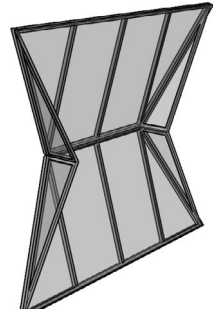

Ground Floor Open

# ENVELOPE SYSTEM

Fully Enclosed

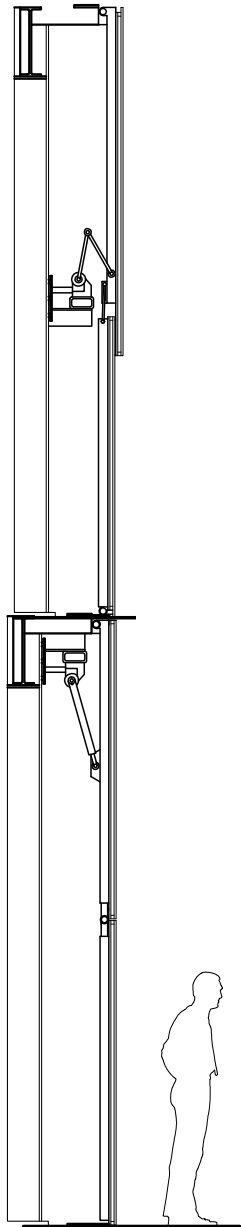

Operable Units

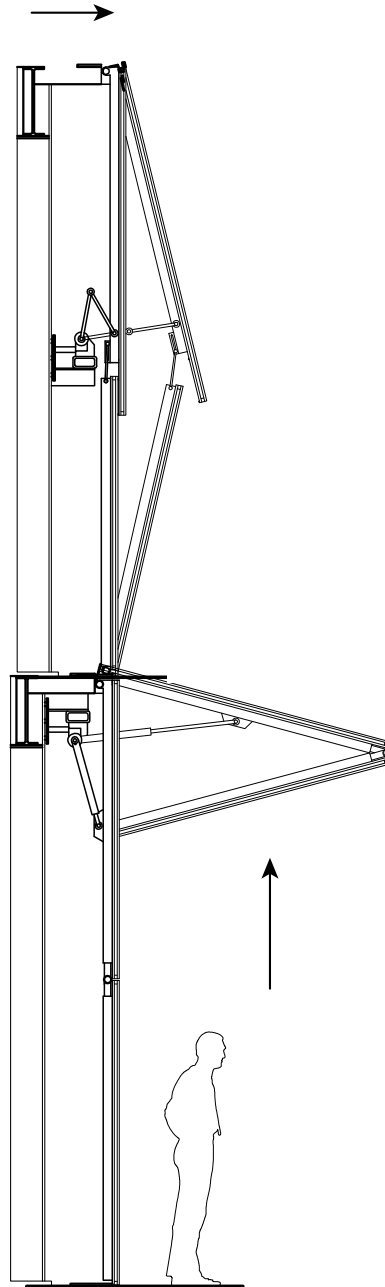

Fully Connected  
to Urban Room

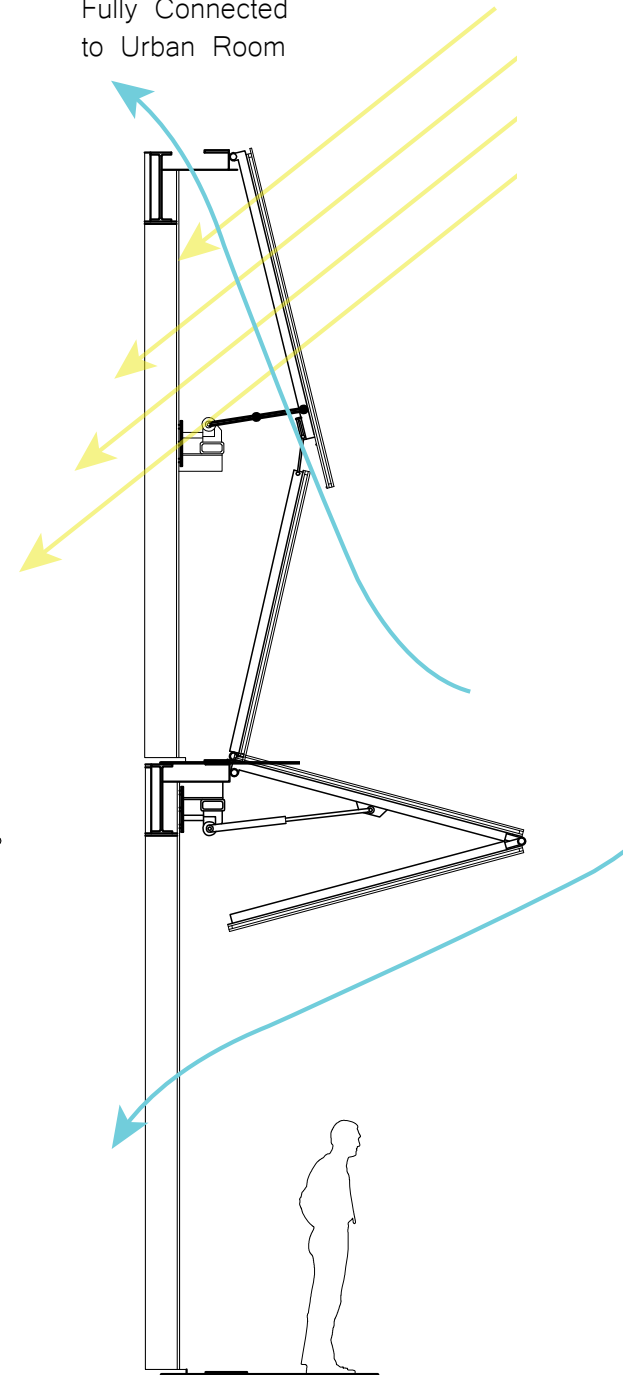

# North and East Elevation

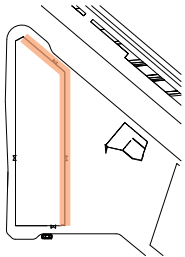
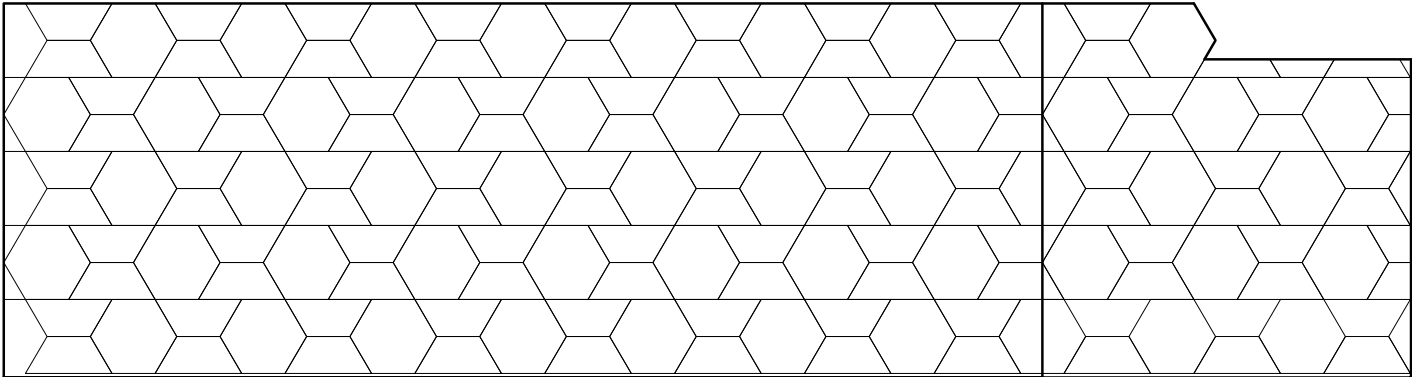

# North and East Elevation

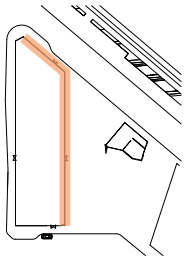
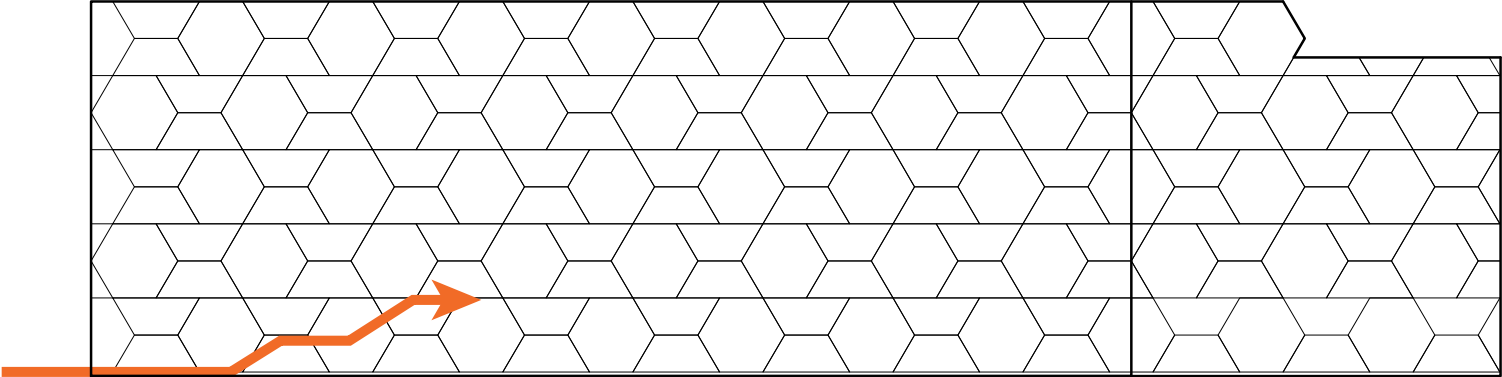



# North and East Elevation

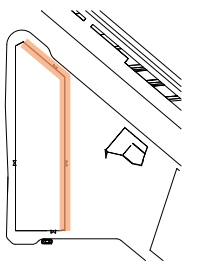
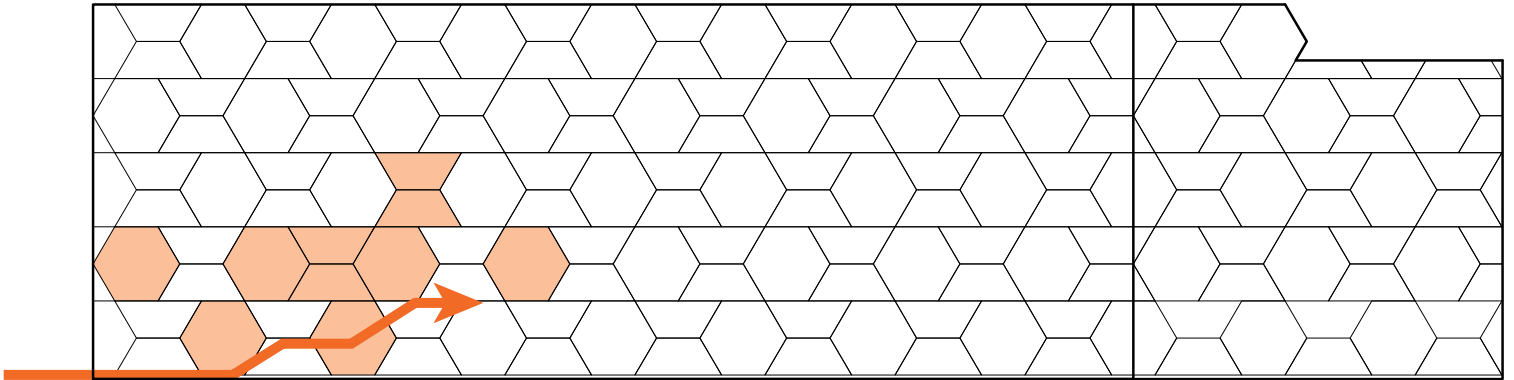

# North and East Elevation

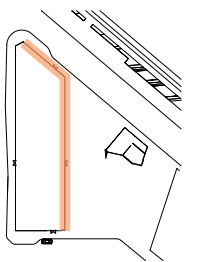
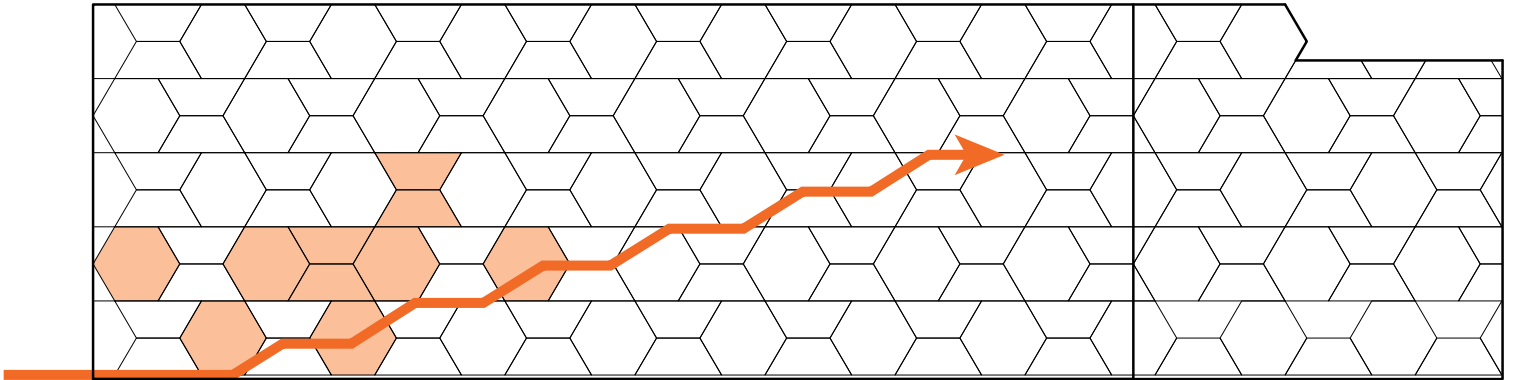

# North and East Elevation

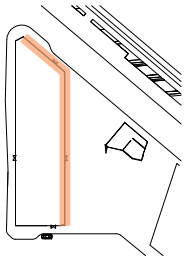
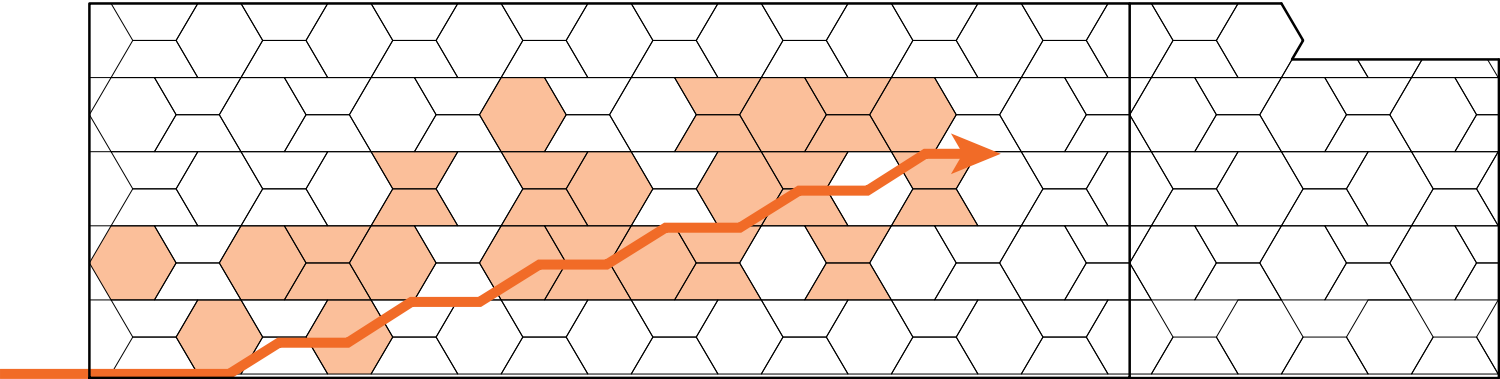

# North and East Elevation

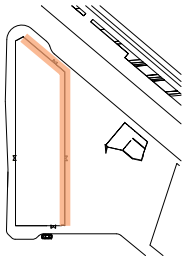
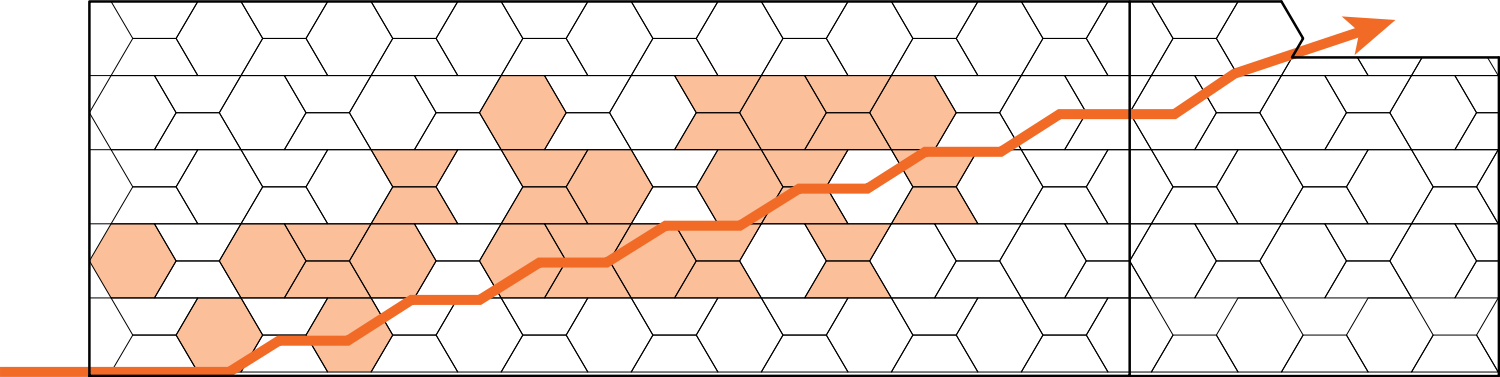



# North and East Elevation

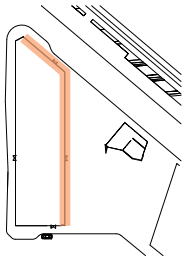
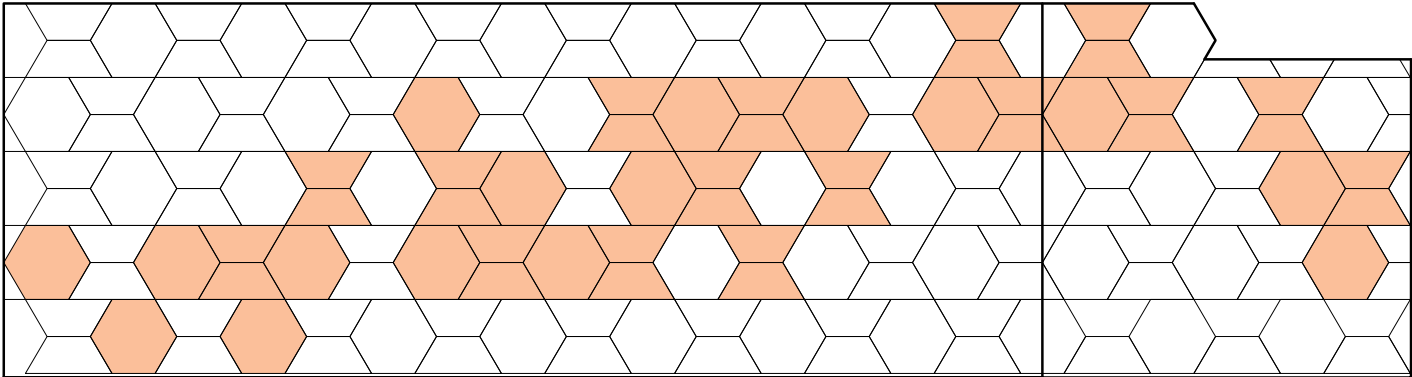



# North and East Elevation

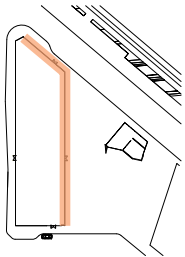
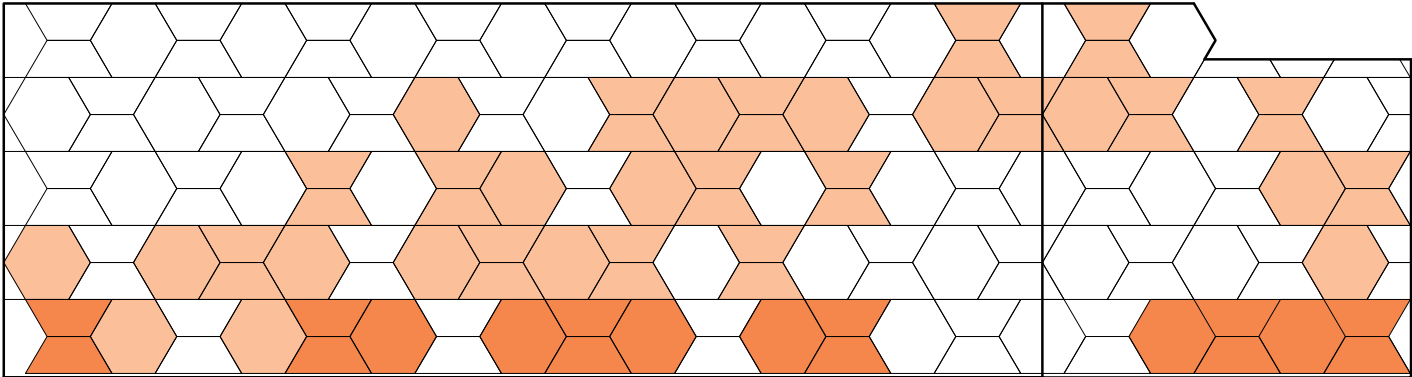

# INNOVATION ECOLOGY

1. Documentation and Analysis
2. Project Synthesis and System Development
3. Site Development
  - Envelope System
  - Urban Architecture
  - Building Development
4. Conclusion

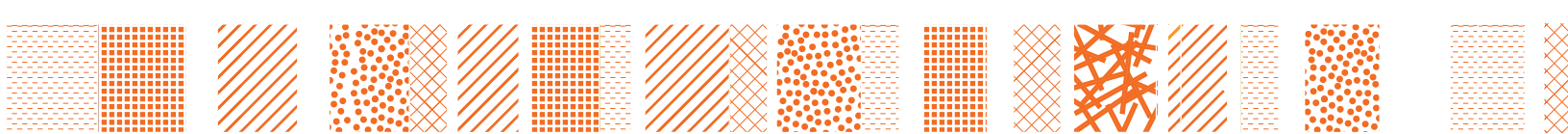
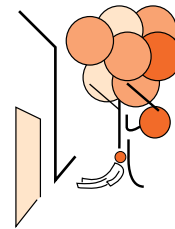

# SITE ANALYSIS

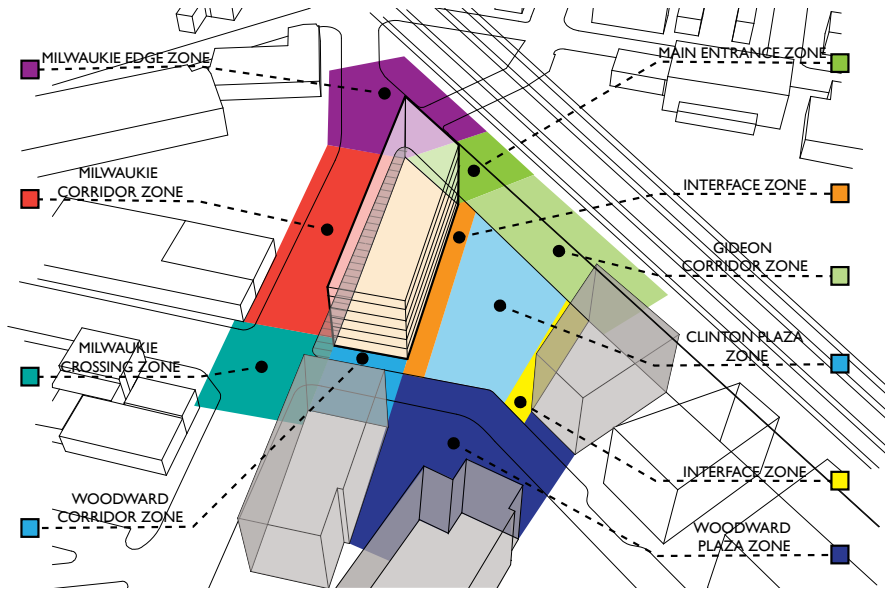

URBAN ROOM PROGRAM ZONES

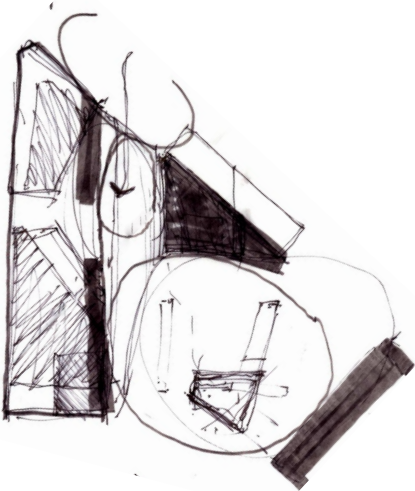

PARTI SKETCH

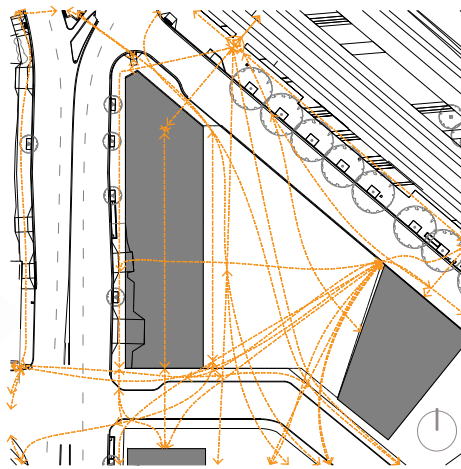

PEDESTRIAN PATHS DIAGRAM

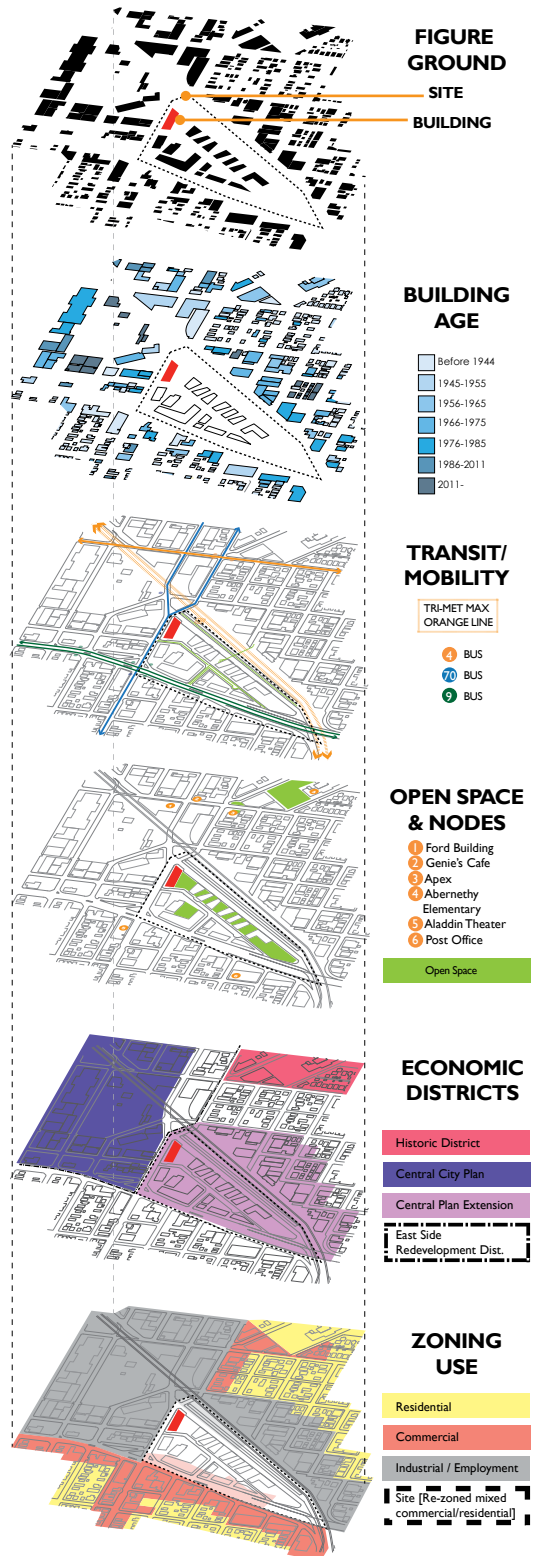



UNILOCK UMBRIANO



LAMBOO RENUWALL



GRASSPAVE2



GRAVELPAVE2

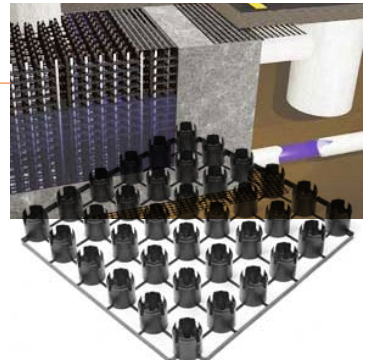

RAINSTORE3



**URBAN ROOM SECTION**  
SCALE: 1/8"=1'-0"

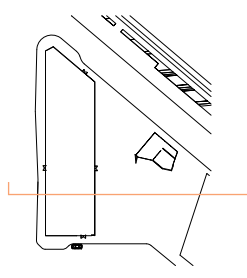
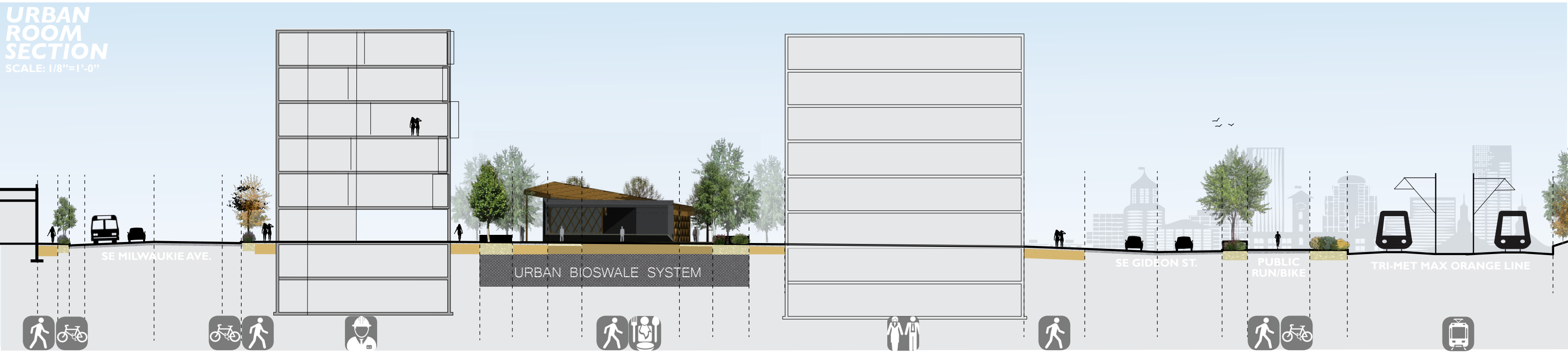

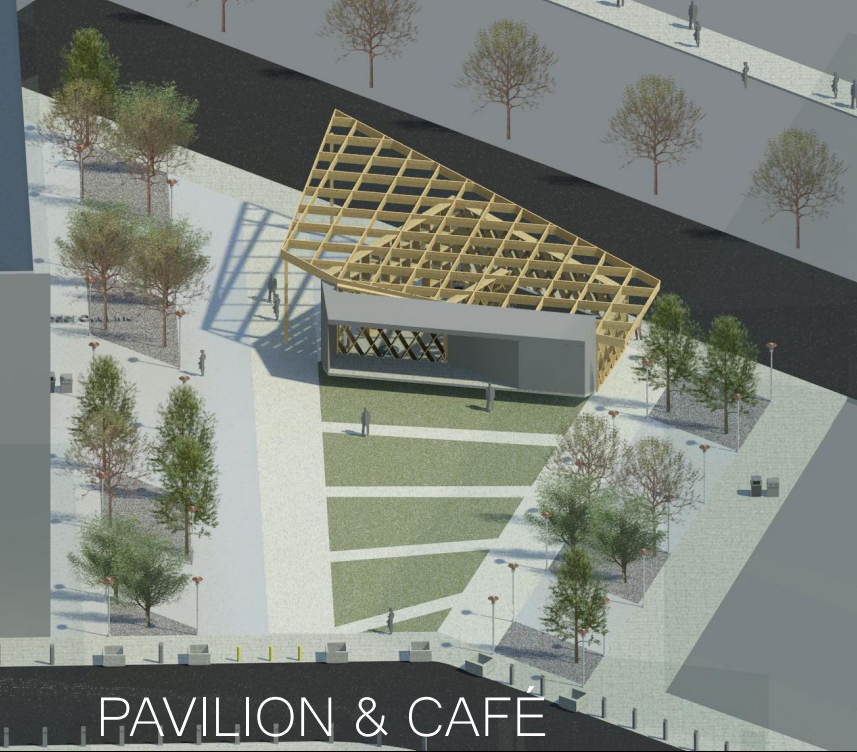

PAVILION & CAFE





# INNOVATION ECOLOGY

1. Documentation and Analysis
2. Project Synthesis and System Development
3. Site Development
  - Envelope System
  - Urban Architecture
  - Building Development
4. Culmination

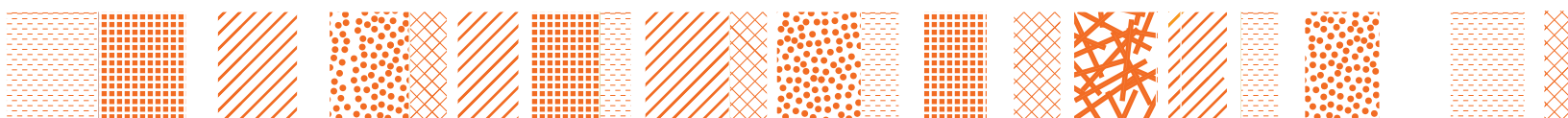
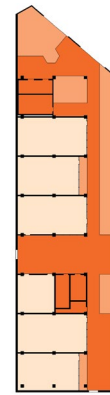

# FLEX MAKER SPACES

Not only is Portland 'weird', but its people are different. Here tenants and makers may find **flexible** display space and a healthy mix of diverse small business owners.

What tenant, or maker, would not want to push their square footage to the max? Those who wish to put their work on display, or offer a spacious and open storefront. Makers who need more space will always need more **space**, so they have the opportunity to physically enhance their business interior square footage.

However, if they wish to put their works on display in an open format, they may prefer to pull in their interior space for a bit of 'street-front' real estate.

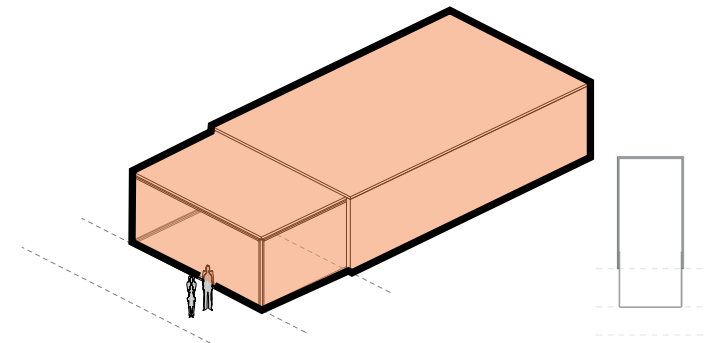

UNIT

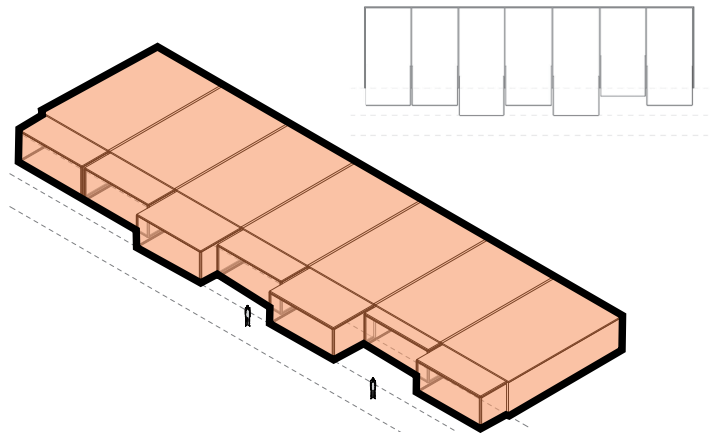

"STREET"

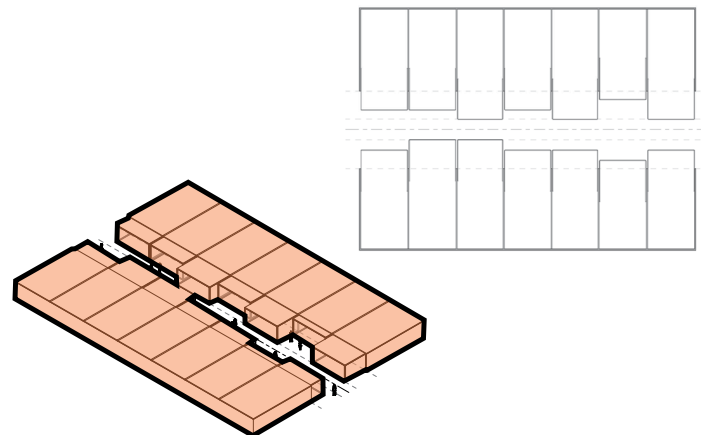

"BLOCK"

# VERTICAL STREET CONCEPT

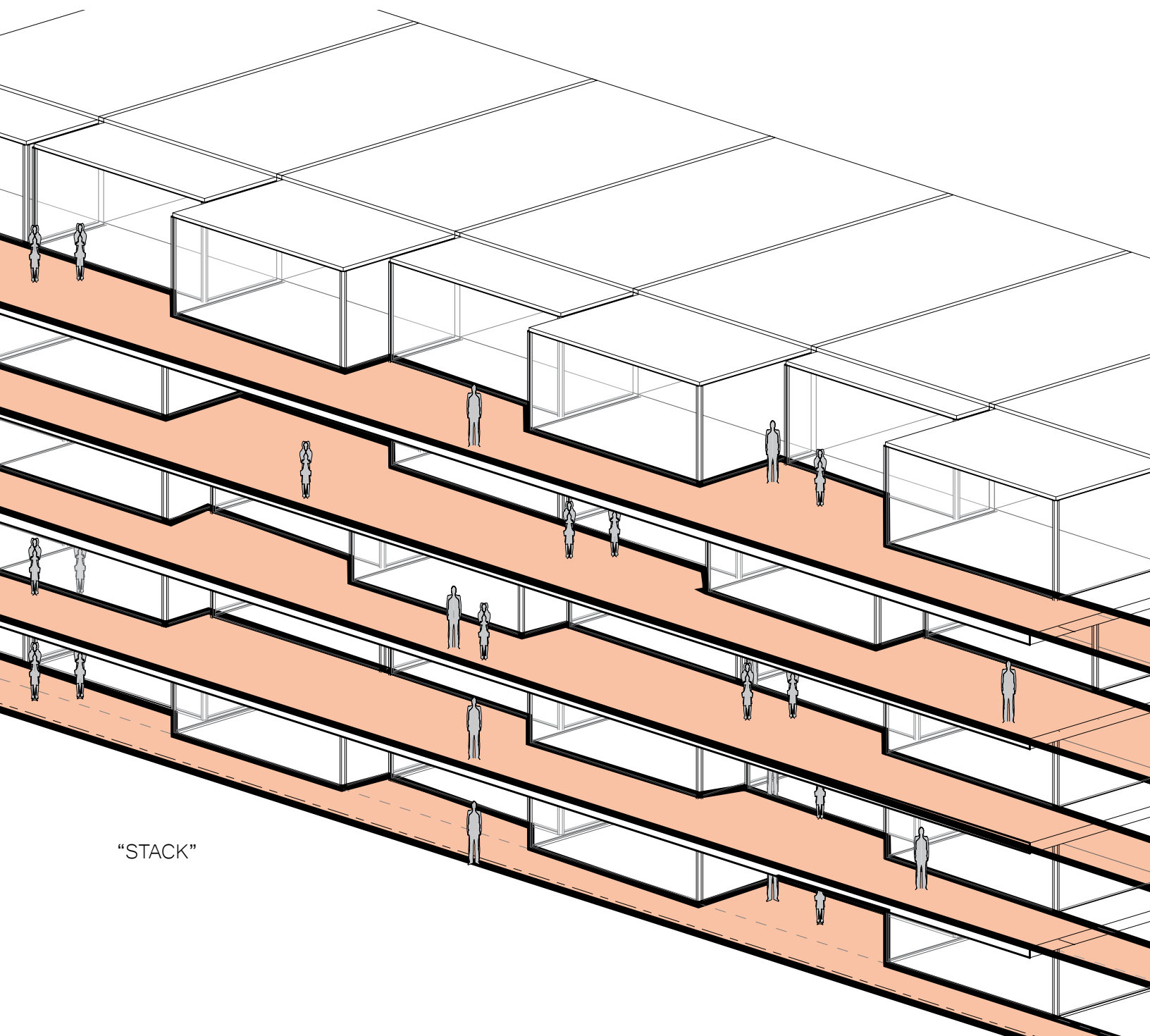

“STACK”

# BUILDING FLOOR PLAN

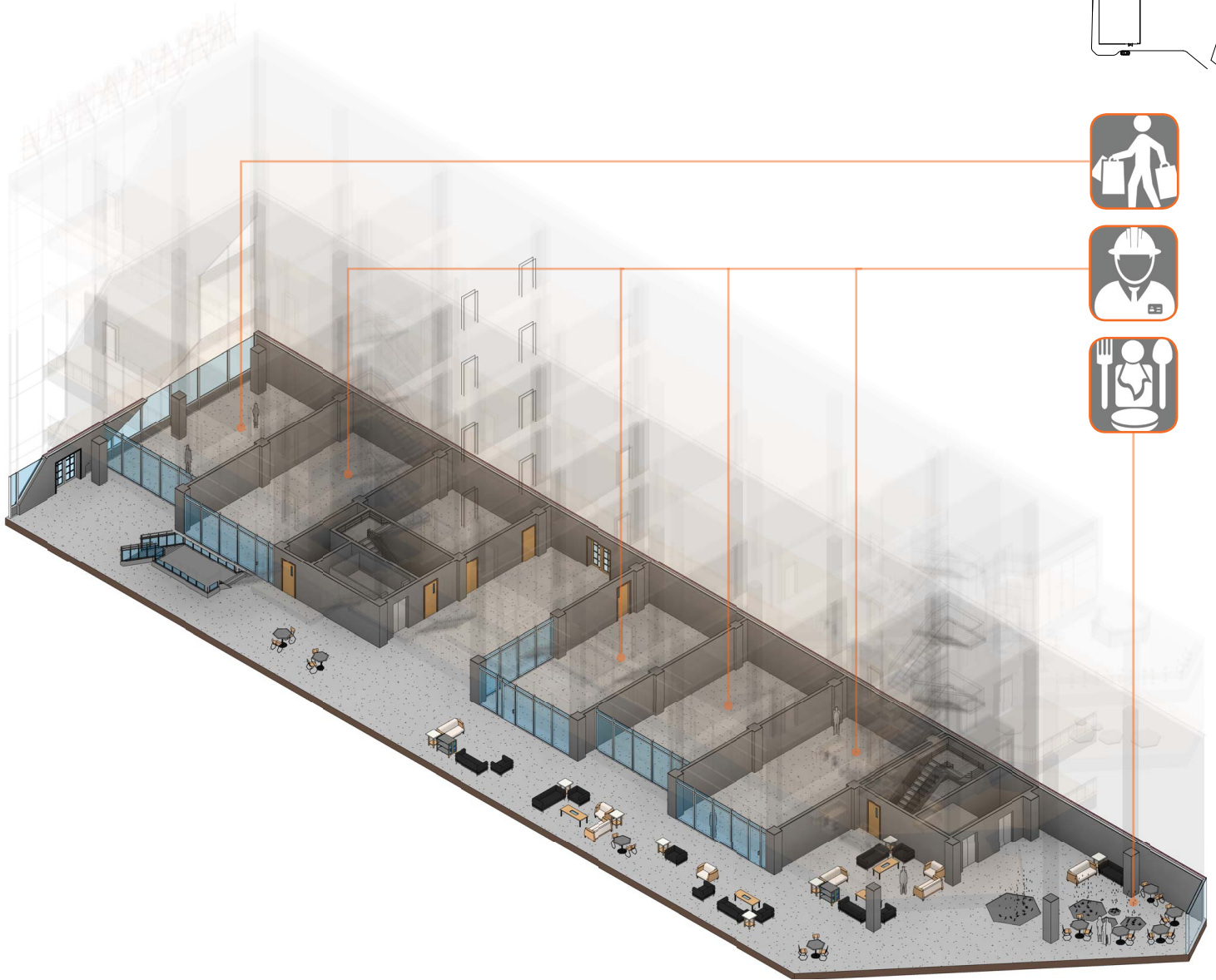
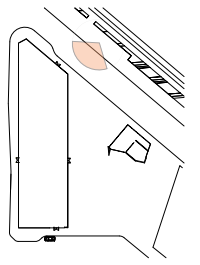

LEVEL 1

# BUILDING FLOOR PLAN

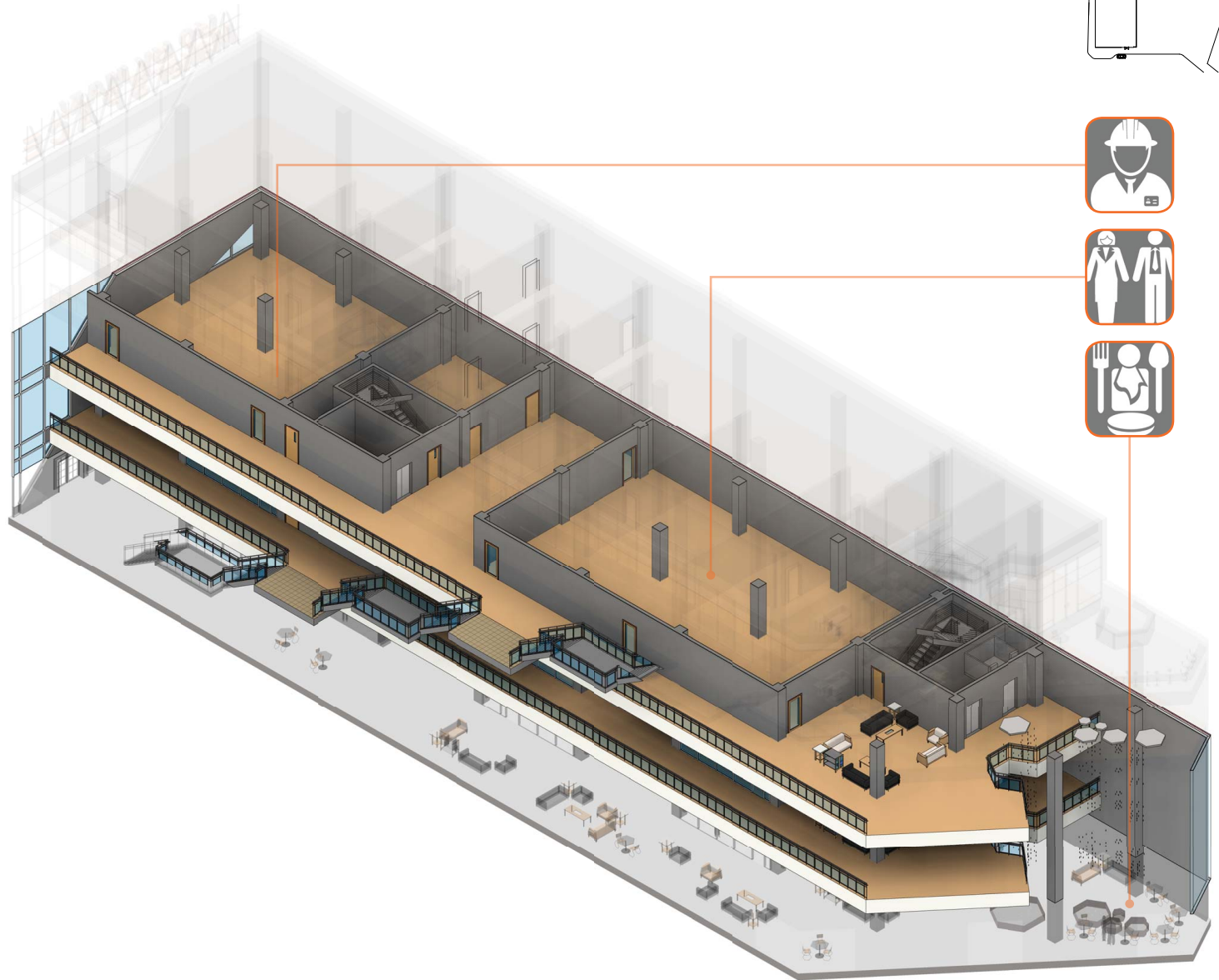
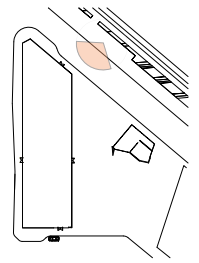





LEVEL 3

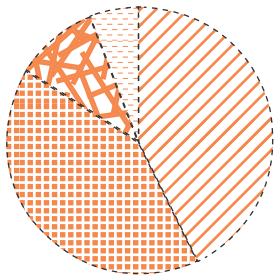
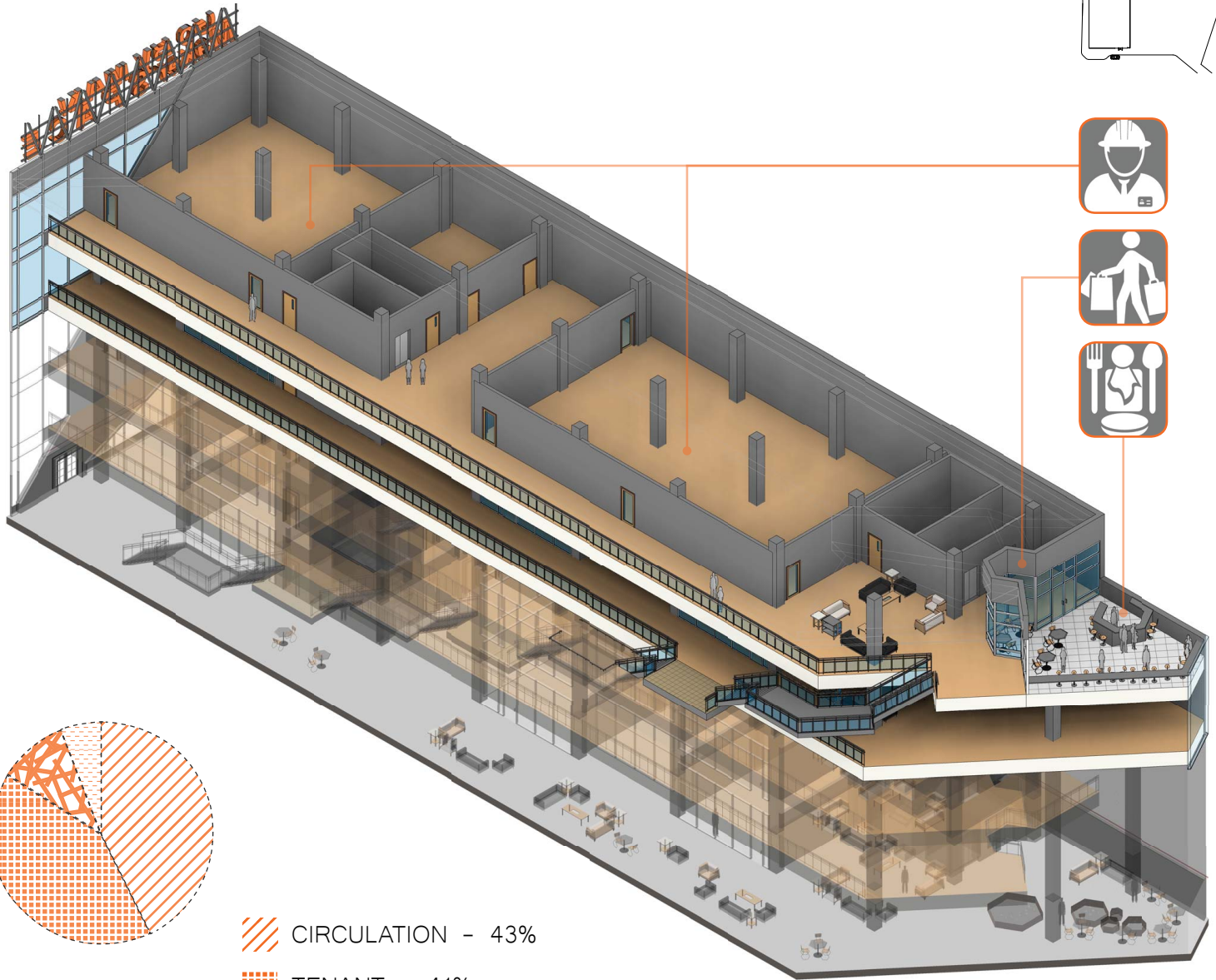
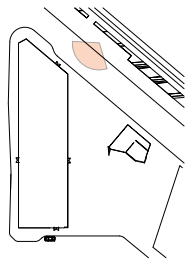

# BUILDING FLOOR PLAN



-  CIRCULATION - 43%
-  TENANT - 41%
-  THIRD SPACE - 10%
-  MECH. - 6%

LEVEL 5

BLDG. FOOTPRINT: 14,493 SF  
TOTAL NET: 55,913 SF



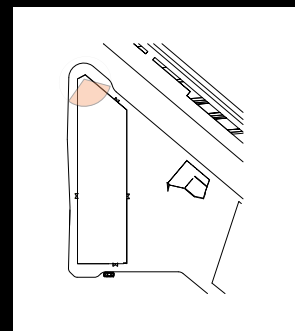

# INNOVATION ECOLOGY

1. Documentation and Analysis
2. Project Synthesis and System Development
3. Site Development
  - Envelope System
  - Urban Architecture
  - Building Development
4. Culmination

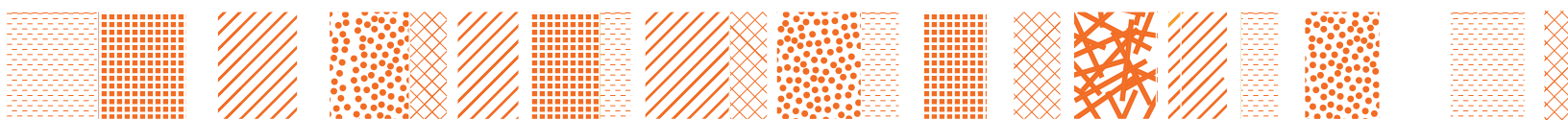

# SOUTH SECTION PERSPECTIVE

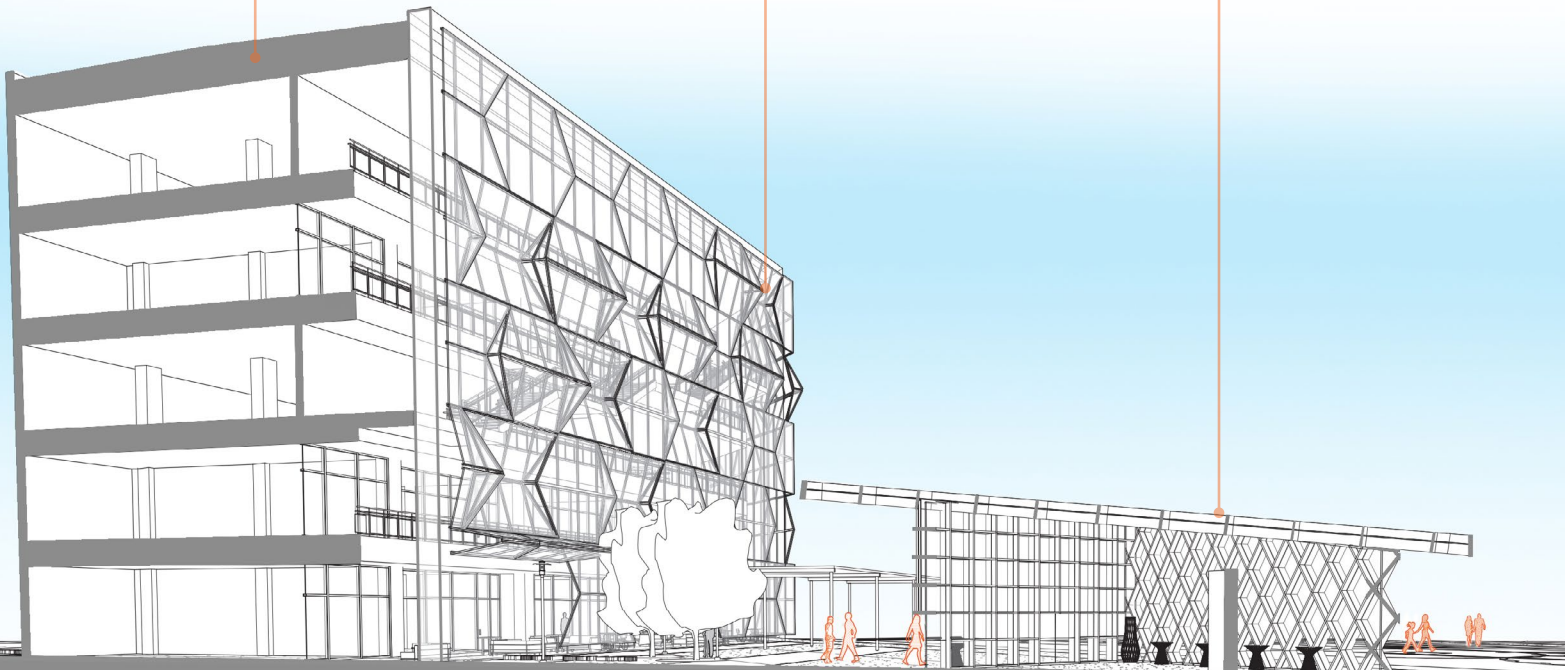
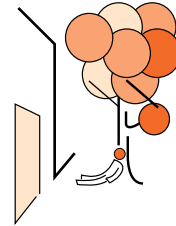
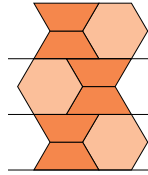
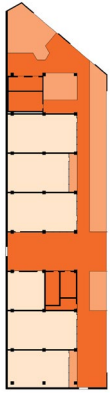
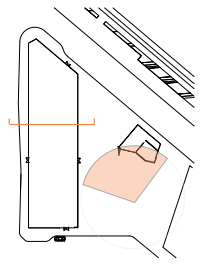

# NORTH TERRACE/ORANGE LINE

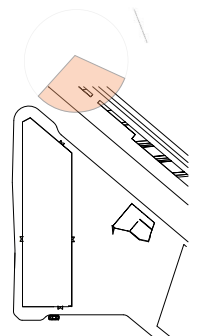
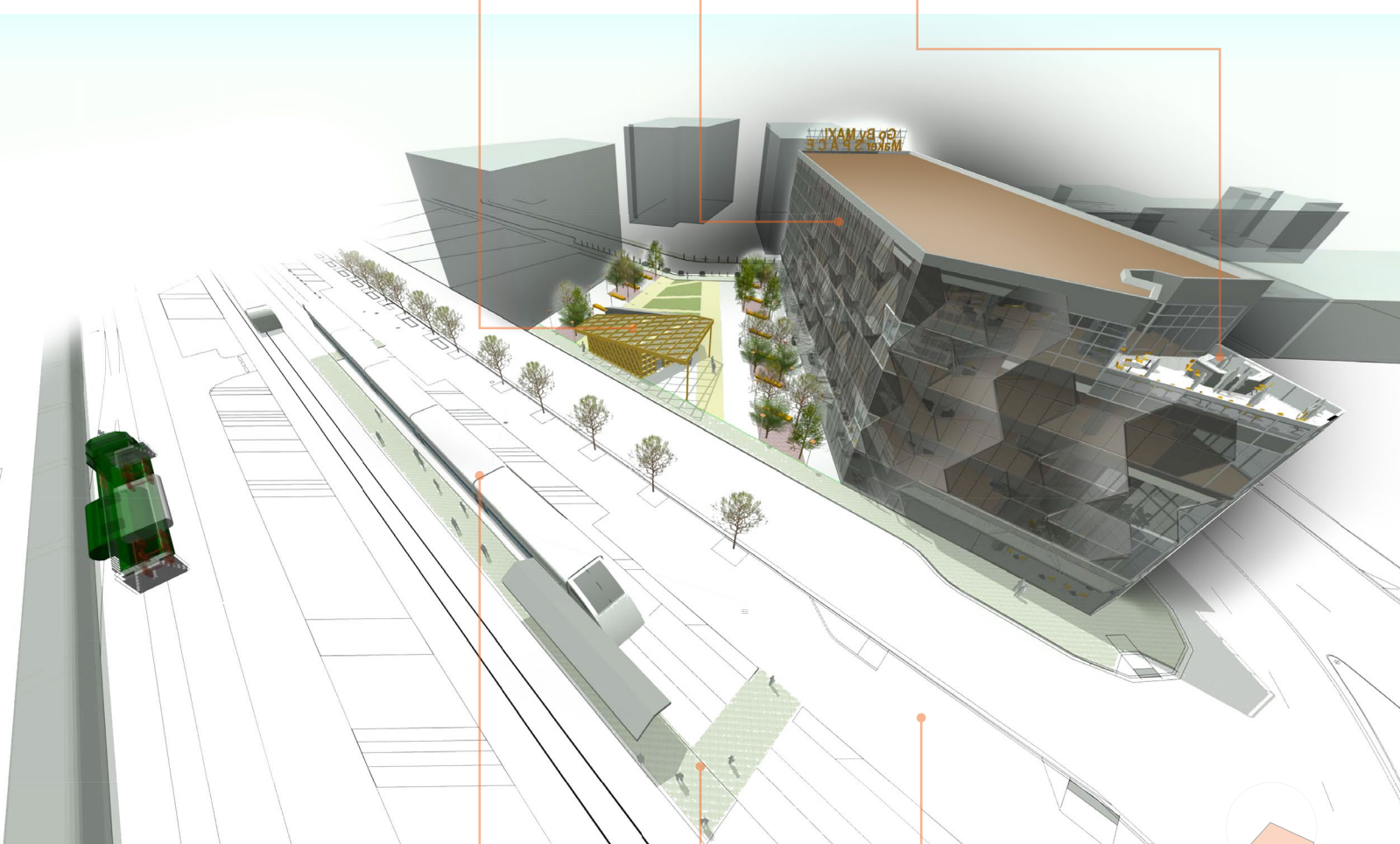





NEONspace





THANK YOU

*Al Lambi* 2.5.14

A stylized signature or scribble in red ink, consisting of several overlapping horizontal and diagonal lines.

*Rick* 2014/02/05

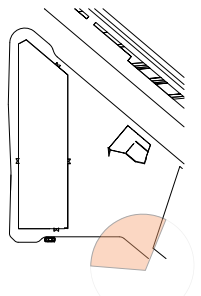



# INNOVATION ECOLOGY

Milwaukie Alignment Portland, Oregon

